

USER MANUAL

Solar Battery Pack

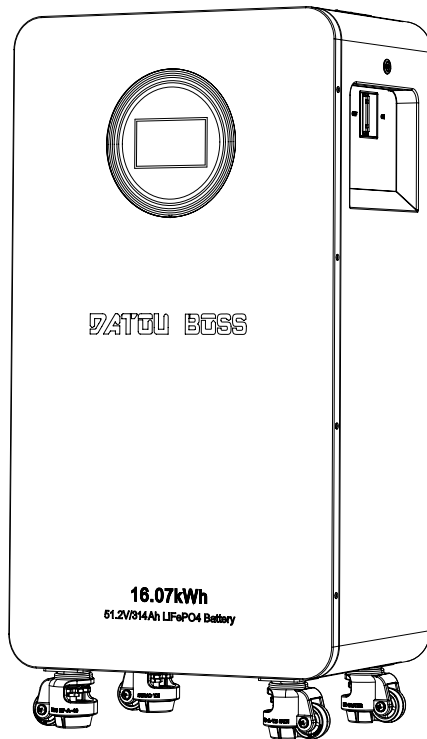

1. Usage Safety Instructions

Please keep this manual properly for future reference. It details the installation and operation standards for the solar product pack. Before installation or use, be sure to read all instructions and precautions carefully.

1.1 Safety Warnings

There are non-safe voltages inside the solar product pack, and it is strictly prohibited for users to disassemble it privately. In case of equipment failure and need for maintenance, please contact professional maintenance personnel in time.

1.2 Precautions for Use

1. Avoid immersion of the product in water or exposure to moisture.
2. Prohibit charging the product near fire sources and in high-temperature environments, and avoid using or storing the product near heat sources such as heaters.
3. If leakage or abnormal odor is detected, immediately transfer the product to a safe, open area.
4. Use the designated charging cable; if replacement is needed, ensure it matches the original wire gauge.
5. Pay attention to the correct polarity during installation; do not connect in reverse.
6. Do not connect the product directly to wall sockets or car cigarette lighter sockets.
7. Do not place the product in a fire or heat it.
8. Avoid using wires or other metal objects to short-circuit the product terminals. Do not transport or store the product along with necklaces, hairpins, or other metal objects.
9. Do not pierce the product with nails or sharp objects, and do not strike or step on the product.
10. Avoid impacts, throwing, or other mechanical shocks.
11. Do not weld directly onto the product terminals.
12. Do not disassemble the product by any method.
13. Do not mix this product with original products (such as dry cells), or with different capacities, models, or types.
14. If the product has been left unused in storage for more than 3 months, perform recharging.

1.3 Abnormal Situations

1. If leakage or odor is detected, immediately move the product to an open and safe area. If the electrolyte comes into contact with your eyes, do not rub, flush with plenty of water and seek medical attention immediately.
2. If the product is hot, deformed, discolored or has other abnormalities, please stop using it, and if it is charging/discharging, remove the product immediately.
3. If the product smokes or catches fire, please ensure your own safety and quickly move the product to a fireproof and open place (e.g., sand, metal container).

1.4 Environmental Tips

Discharged batteries should be recycled according to local regulations. Do not dispose of them at will.

2 Installation Instructions

2.1 Unpacking and inspection

Inspect the unit before installation. Make sure there is no damage in the package. You should receive the following items in the package:



Solar Battery Pack

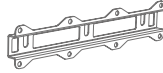

Mounting Bracket x1



Short Screws x3



Short Screws x2



Expansion Screws x8



User Manual x1

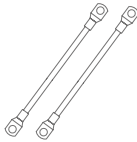

Positive and Negative Leads



Communication Cable x1

2.2 Preparator work (installation in the of state, it is recommended that the installation of equipment to find a professional electrician installation)

Wall-mounted Before selecting a mounting location, consider the following points:

- ① . Do not install the all-in-one on flammable building materials.
- ② . Do not install the product in a harsh environment.
- ③ . Mounted on a sturdy surface.
- ④ . Install the All-in-One at eye level so that the LCD display can be read at all times.
- ⑤ . The ambient temperature should be between 0°C and 55°C to ensure optimal operation.

- ⑥ . Vertical mounting on the wall is recommended.
- ⑦ . Be sure to retain the other objects and suraces shown at right to allow for adequate heat dissipation and enough room to remove the wires.
- ⑧ . Before connecting all wiring, remove the bottom cover by unscrewing the two screws as shown below.



WARNING !

Requires the product to be installed with the power off and disconnected.

2.3 Installation Steps

Wall-mounted Before selecting a mounting location, consider the following points:

- ① . Check that all wires are wired as specified.
- ② . Before using the product, it must be used in accordance with the requirements of the parameters within the manual.

Note: that the air switch is in the "ON" state, then press the key to turn on the product, the product can be used normally.

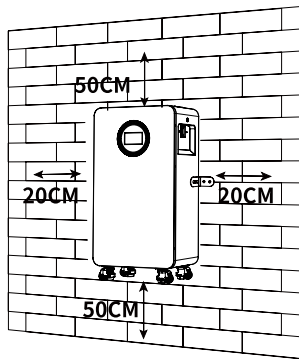

- Requires the product to be installed with the power off and disconnected.
- All wiring work must be carried out by qualified personnel.

3. Specification

Total Energy	16.07 KWh
Internal Resistance	≤13.9mΩ
Single Battery Capacity	314Ah
Nominal Operating Voltage	51.2V
Standard Input Current	210A
Standard Output Current	157A (210A Max)
Overpressure Protection	58.4V
Overcharge Protection Recovery	54.0V
Over-discharge Protection	43.2V
Over-discharge Protection Recovery	46.4V
High-temperature Charging Protection	55°C
High-temperature Charging Recovery	50°C
Low-temperature Charging Protection	0°C
Low-temperature Charging Recovery	5°C
High-temperature Discharge Protection	55°C
High-temperature Discharge Recovery	50°C
Low-temperature Discharge Protection	-20°C
Low-temperature Discharge Recovery	-15°C
Overcurrent Protection (Charging)	215A
Overcurrent Protection (Discharging)	215A
Short Circuit Protection	Yes, method via "load removal and charge disconnection"
Power Delivery Rate	40% to 60%
Equalization	Passive balancing
Power Consumption when Off	≤300μA
Cycle Life	≥8000 Cycle , 70% SOH 25°C
	≥3000 Cycle , 70% SOH 45°C
Protection Level	IP20
Communication Protocols	RS232, RS485, CAN
Dimensions (L×W×H)	453×260×879 mm
Weight	113 kg

4. Function Introduction

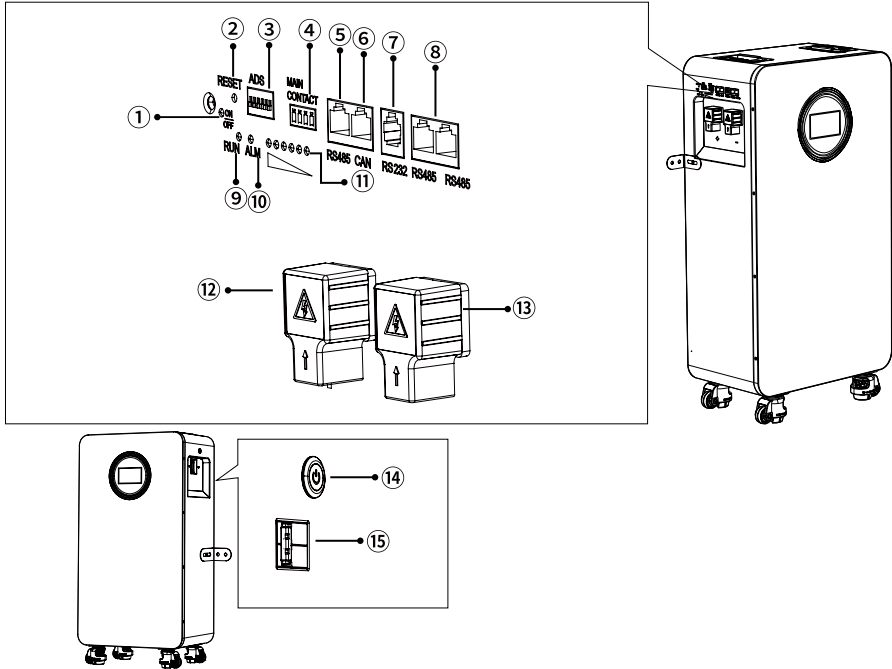

Number	Functionality	Descriptive
①	Switch Indicator Lights	Switch Status
②	Reset switch	Reboot or shutdown when pressed
③	DIP Address	Parallel or communication address selection
④	Dry contact	Normally open or normally closed signal driven relay
⑤	RS485	External communications
⑥	CAN	External communications
⑦	RS232	Alternate communications port
⑧	RS485-1&RS485-2	Internal communication or battery parallel use
⑨	Operation Indicator	Operational status
⑩	Alarm Indicator	Alarms
⑪	Battery indicator	Battery level indication
⑫	Battery Positive	Battery Positive
⑬	Battery Negative	Battery negative
⑭	Mains Switch	Control switch
⑮	Air switch	Disconnect input and output

4.1 Table 1 LED Indicator Description

Table 1 LED Indicator Description





Status	Item	ON/OFF LED9	RUN (LED8)	ALARM (LED7)	SOC(LED6~1)	Description
						
Power Off	Sleep Mode	OFF	OFF	OFF	OFF	All LEDs off
Static state	Normal	ON	Flash 1	OFF	Refer to Table 2	/
	Alarm	ON	Flash 1	Flash 3		
Charging	Normal	OFF	OFF	OFF		Over-voltage alarm, no blinking
	Alarm	ON	ON	Flash 3		
	OV protect	ON	ON	OFF	ON	
Discharging	Temperature, Over-current, fail-safe)	ON	OFF	ON	OFF	/
	Normal	ON	Flash 3	OFF	Refer to Table 2	
	Alarm	ON	Flash 3	Flash 3		
	UV Protection	OFF	Flash 2	OFF	OFF	
	Overcurrent, Short Circuit, Temperature, Fault Safety	ON	OFF	ON	OFF	

Table 2 SOC Indicator Description















State		Charging						Discharging					
LED	LED	ED6	LED5	LED4	LED3	LED2	LED1	LED6	LED5	LED4	LED3	LED2	LED1
													
SOC(%)	0~16.6%	OFF	OFF	OFF	OFF	OFF	Flash 2	OFF	OFF	OFF	OFF	OFF	ON
	16.6~33.2%	OFF	OFF	OFF	OFF	Flash 2	ON	OFF	OFF	OFF	OFF	ON	ON
	33.2~49.8%	OFF	OFF	OFF	Flash 2	ON	ON	OFF	OFF	OFF	ON	ON	ON
	49.8~66.4%	OFF	OFF	Flash 2	ON	ON	ON	OFF	OFF	ON	ON	ON	ON
	66.4~83.0%	OFF	Flash 2	ON	ON	ON	ON	OFF	ON	ON	ON	ON	ON
	83.0~100%	Flash 2	ON	ON	ON	ON	ON	ON	ON	ON	ON	ON	ON
RUN LED 		ON						Blinks 3					

Table 3 LED Indicator Description

Mode	ON	OFF
Flash 1	0.25S	3.75S
Flash 2	0.5S	0.5S
Flash 3	0.5S	1.5S

4.2 Description of Buzzer Action

- ① . When a fault occurs, a 0.25S signal is emitted every 1 second.
- ② . During protection, a 0.25S horn is emitted every 2 seconds (except for overpressure and underpressure protection).
- ③ . When an alarm is issued, a 0.25S alarm is emitted every 3 seconds (except for overpressure or underpressure alarms).

4.3 Reset Switch Description

Corresponding icon:

RESET



- ① . When the BMS is in sleep mode, press the switch (1S) to turn it off, and the protection board is activated. The LED indicator will light up for 0.5 seconds.
- ② . When the BMS is active, press the switch (3 to 6 seconds), and the LED indicator will light up from the minimum power indicator to maximum power indicator for 0.5 seconds. After turning off, the system will enter sleep mode.
- ③ . When the BMS is active, press the button (6-10 seconds) and release to reset the board. The LED indicator will reflect the current power display.

4.4 Mains Switch Instructions

Corresponding icon:



- ① . When the BMS is in hibernation state, after turning off the main switch, the protection board is energized, and the LEDs are lit sequentially starting from "LED1" for 0.5 seconds.
- ② . When BMS is active, turn off the main switch and wait for 1S-3S, then the system will enter the power-off state.

4.5 Communication Functions

Interface Description:

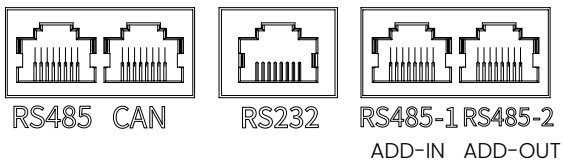

Interface	RS485-1		CAN1		RS232		RS485	
Functional Description	Connection to host computer or inverter		Connection to host computer or inverter		Parallel communication		Parallel communication	
Pin Descriptions	Pin	Descriptions	Pin	Descriptions	Pin	Descriptions	Pin	Descriptions
	1, 8	RS485-B1	1, 8	NC	1, 2, 6	NC	1, 8	RS485-B2
	2, 7	RS485-A1	2, 7	NC	3	TX	2, 7	RS485-A2
	4	NC	4	CANHI	4	RX	4	NC
	5	NC	5	CANLI	5	GND	5	NC(L)/OUT(R)
	3, 6	GND	3, 6	GND			3, 6	GND

4.6 Dip Switch

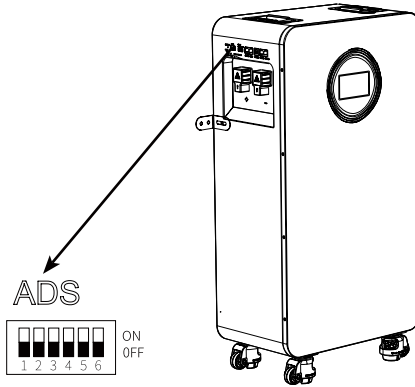

When connecting battery packs in parallel, use the DIP switch on the BMS to set the address to distinguish different data packets. The maximum number of parallel units is 15, of which 5 and 6 are reserved and have no function.

Address bit (binary)	Explain				
	4	3	2	1	
0001(1)	OFF	OFF	OFF	ON	Set PACK1 to be used by a host or single machine
0010(2)	OFF	OFF	ON	OFF	Set PACK2
0011(3)	OFF	OFF	ON	ON	Set PACK3
0100(4)	OFF	ON	OFF	OFF	Set PACK4
0101(5)	OFF	ON	OFF	ON	Set PACK5
0110(6)	OFF	ON	ON	OFF	Set PACK6
0111(7)	OFF	ON	ON	ON	Set PACK7
1000(8)	ON	OFF	OFF	OFF	Set PACK8
1001(9)	ON	OFF	OFF	ON	Set PACK9
1010(10)	ON	OFF	ON	OFF	Set PACK10
1011(11)	ON	OFF	ON	ON	Set PACK11
1100(12)	ON	ON	OFF	OFF	Set PACK12
1101(13)	ON	ON	OFF	ON	Set PACK13
1110(14)	ON	ON	ON	OFF	Set PACK14
1111(15)	ON	ON	ON	ON	Set PACK15

4.7 Parallel Wiring Instructions

Interface Illustration:

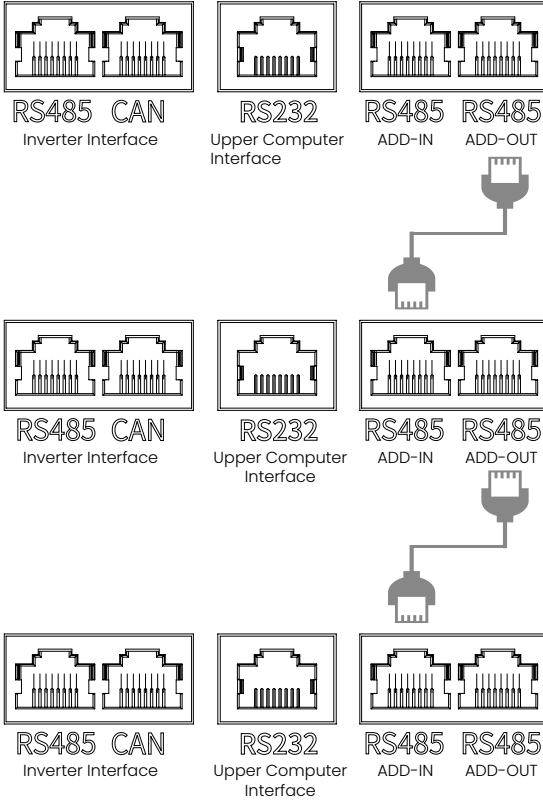

15 parallel groups

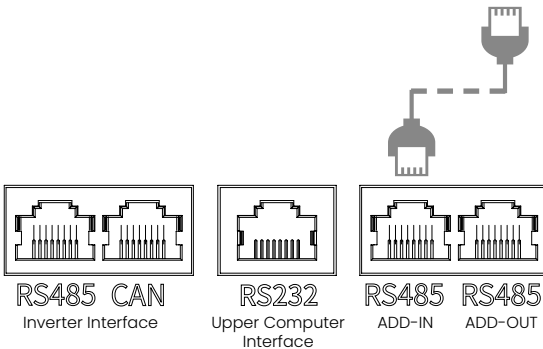

5. Display Description

5.1 Starting Screen



5.2 Main Screen

The main page displays parallel statistics such as average SOC, maximum and minimum battery voltage, maximum and minimum battery temperature, average battery voltage and total system current, average remaining system power, operating power, MOS charging and discharging status, and language switching functions.



5.3 Language

The system supports switching between English and Chinese, and the switching button is located at the top right corner of the homepage.

6.4 Slave

After switching to the Slave Device page, the upper part displays the version selection, the middle part visualizes the battery level and SOH data, the middle part displays the battery voltage and current, the charge/discharge status and the fault indication status, and the lower part displays the battery level and temperature data of the Slave Device as well as the ambient temperature and MOS temperature data.

Slave address description background color: blue indicates the selected slave controller, green indicates the online slave controller, and white indicates the offline slave controller.



6.5 Parameter Setting

In the parameter setting page, you can set the battery voltage and undervoltage parameter, total voltage and undervoltage parameter, ambient high temperature and low temperature parameter, overvoltage differential parameter, charging overcurrent parameter, discharging overcurrent parameter, MOS high temperature parameter, charging high temperature and low temperature parameter, discharging high temperature and low temperature parameter, and SOC high temperature parameter.

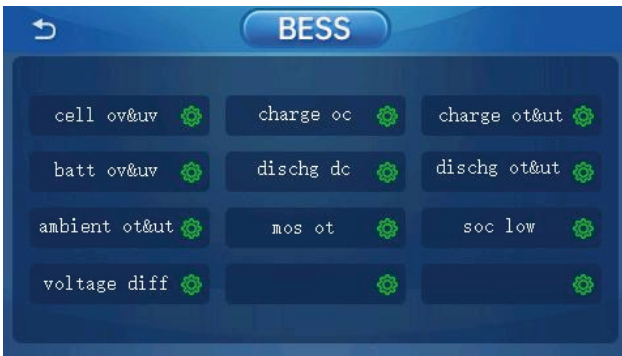

6.6 Protocol Setting

CANprotocolselection: Supportplyon、growatt、goodwe、sofarsolar、victron、voltronic、lxp、deye、ginlong、sma.

RS485 protocolselection: Supportplyon、growatt、Voltronic、lxp、deye、invent、srna.



5.7 System Setting



6. Warranty Description

Please read the instructions carefully and keep them in a safe place.

1. This product will be repaired if it malfunctions during the warranty period for normal use in accordance with the operating instructions. The parts replaced during the warranty period are the property of our company.
2. For replacement or warranty, please send this warranty card together with the product.
3. No free repairs will be made during the warranty period if any of the following conditions apply.
 - ① . Damage caused by failure to comply with the requirements of the instruction manual for use, maintenance and repair, or the use of non-original parts.
 - ② . Failure or damage caused by improper storage and custody (product battery failure due to not recharging the product for a long period of time);
 - ③ . Failure or damage caused by the use of power supply equipment and load rated equipment not within the specified voltage range.
 - ④ . Failure or damage caused by private repair, dismantling or modification.
 - ⑤ . Damage to the surface coating and exterior is not covered by the warranty.
 - ⑥ . Product outer packaging and product accessories are not covered by the warranty.
 - ⑦ . Torn, altered or unrecognizable product labels, seals and serial numbers (SN).
4. Failure or damage due to force majeure (force majeure refers to an objective event that cannot be foreseen, avoided or overcome.
This includes natural disasters such as floods, fires, explosions, lightning, earthquakes and storms, as well as social events such as wars and disturbances).
5. This manual is for use only in (this sales area), the final interpretation right belongs to the company.
6. Please keep this manual in a safe place as it will not be distributed separately to users.
7. If the name of the distributor is not written or stamped, ask the distributor from whom you purchased the product for proof of the date of purchase and the name of the distributor, and issue a receipt to the distributor. If you do not have such proof, please contact your dealer or the company from which you purchased the product. If you purchased the product from our online store, please be sure to provide proof of the date of purchase, such as an invoice, order number, or a screen shot of your order history.

7. Reimbursable Service Warranty

Because the product does not meet the warranty conditions need to be charged, the company will be based on parts and labor costs to calculate the appropriate repair costs, and put forward a repair quote to you, after obtaining your consent and payment of the cost to provide repair services for your product.

PRODUCT WARRANTY CARD	
This card is a product warranty certificate, please be sure to keep it properly.	
Product Name	
Manufacturing Number	
Purchasing Date	
Dealer Name	
Dealer Address	
Customer Name	
Customer Address	
Customer Phone Number	
Customer Email	