

USER MANUAL

Hybrid

Solar Inverter

DATOU BOSS

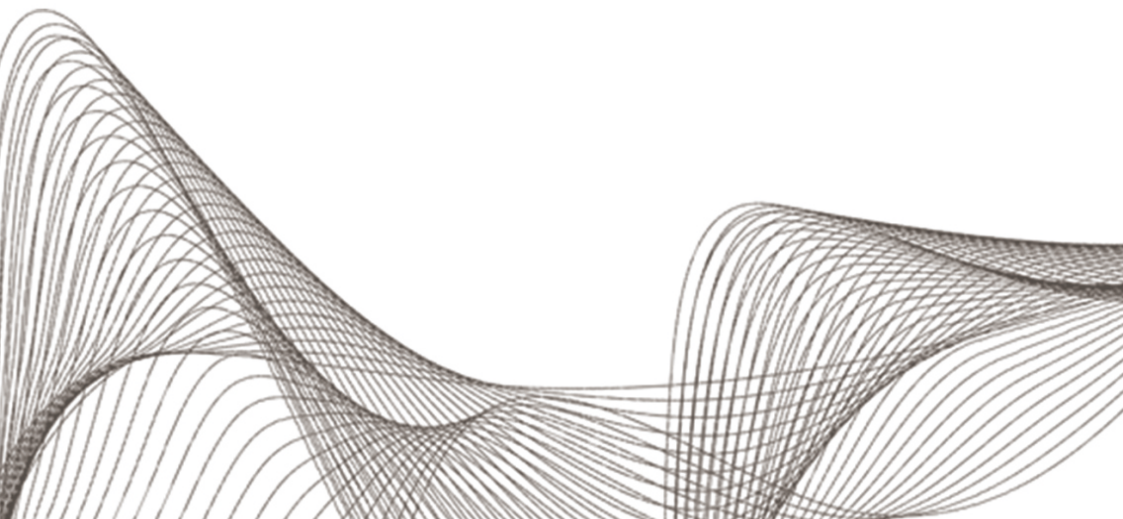

Table Of Contents

1 About This Manual	1
1.1 Purpose.....	1
1.2 Scope.....	1
2 Safety Instructions	1
3 Introduction	2
3.1 Features.....	2
3.2 Basic System Architecture.....	2
3.3 Product Overview.....	3
4 Installation	5
4.1 Unpacking And Inspection	5
4.2 Preparation	5
4.3 Mounting The Unit.....	5
4.4 Battery Connection.....	6
4.5 Ac Input/Output Connection.....	7
4.6 PV Connection.....	8
4.7 Final Assembly.....	10
5 Operation	10
5.1 Power On/off.....	10
5.2 Operation and Display Pane	11
5.3 LCD Setting.....	17
5.4 Battery Equalization Description.....	25
5.5 Fault and alarm description.....	27
6 Trouble removal	29
7 Technical datasheet	30

1 About This Manual

1.1 Purpose

This manual describes the assembly, installation, operation and troubleshooting of this unit. Please read this manual carefully before installations and operations, Keep manual for future reference.

1.2 Scope

This manual provides safety and installation guidelines as well as information on tools and wiring.

2 Safety Instructions



WARNING: This chapter contains important safety and operating instructions. Read and keep this manual for future reference.

1. Before using the unit read all instructions and cautionary markings on the unit, the batteries and all appropriate sections of this manual.
2. **CAUTION**-To reduce risk of injury, charge only deep-cycle lead acid type rechargeable batteries. Other types of batteries may burst, causing personal injury and damage.
3. Do not disassemble the unit Take it to a qualified service center when service or repair is required. Incorrect re-assembly may result in a risk of electric shock or fire.
4. To reduce risk of electric shock, disconnect all wirings before attempting any maintenance or cleaning. Turning off the unit will not reduce this risk.
5. **CAUTION**-Only qualified personnel can install this device with battery.
6. **NEVER** charge a frozen battery.
7. For optimum operation of this inverter/charger, please follow required spec to select appropriate cable size. It's very important to correctly operate this inverter/charger.
8. Be very cautious when working with metal tools on or around batteries. A potential risk exists to drop a tool to spark or short circuit batteries or other electrical parts and could cause an explosion.
9. Please strictly follow installation procedure when you want to disconnect AC or DC terminals, Please refer to INSTALLATION section of this manual for the details
10. One piece of 150A fuse is provided as over-current protection for the battery supply.
11. **GROUNDING INSTRUCTIONS** -This inverter/ charger should be connected to a permanent grounder wiring system. Be sure to comply with local requirements and regulation to install this inverter.
12. **NEVER** cause AC output and DC input short circuited. Do NOT connect to the mains when DC input short circuits.
13. **Warning!!** Only qualified service persons are able to service this device. If errors still persist after following troubleshooting table, please send this inverter/charger back to local dealer or service center for maintenance.

3 Introduction

This is a multi-function Inverter/charger, combining functions of inverter, solar charger and battery charger to offer uninterruptible power support with portable size. Its comprehensive LCD display offers user-configurable and easy-accessible button operation such as battery charging current, AC/solar charger priority, and acceptable input voltage based on different applications.

3.1 Features

- ◆ Pure sine wave inverter
- ◆ Configurable input voltage range for home appliances and personal computers via LCD setting
- ◆ Configurable battery charging current based on applications via LCD setting
- ◆ Configurable AC/Solar Charger priority via LCD setting
- ◆ Compatible to mains voltage or generator power
- ◆ Auto restart while AC is recovering
- ◆ Overload/Over temperature/short circuit protection
- ◆ Smart battery charger design for optimized battery performance
- ◆ Cold start function

3.2 Basic System Architecture

The following illustration shows basic application for this inverter/charger. It also includes following devices to have a complete running system:

- ◆ Generator or Utility
- ◆ PV modules

Consult with your system integrator for other possible system architectures depending on your requirements.

This inverter can power all kinds of appliances in home or environment, including motor-type appliances such as tube light, fan, refrigerator and air conditioner.

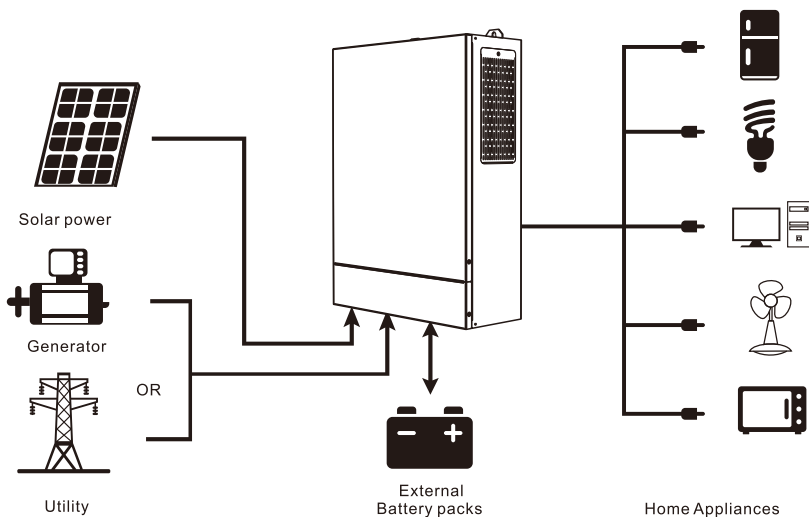

3.3 Product Overview

3.3.1 LCD Screen

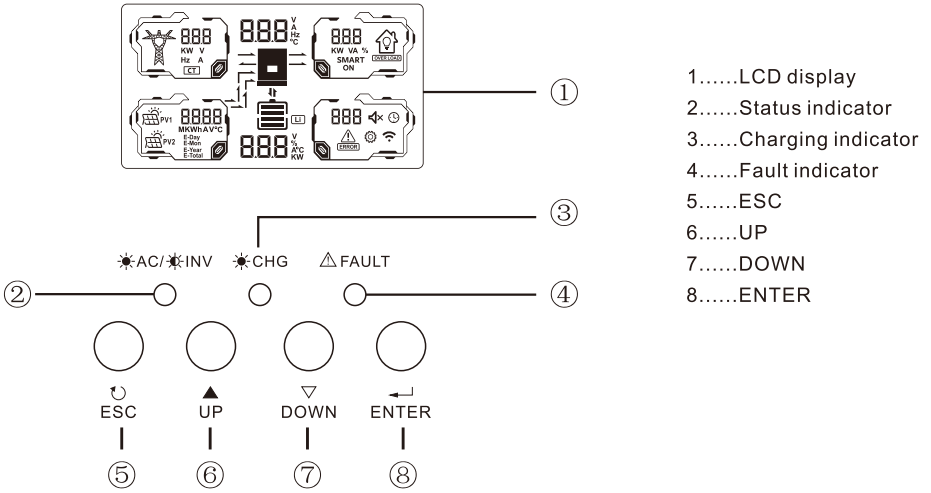

3.3.2 Back Panel

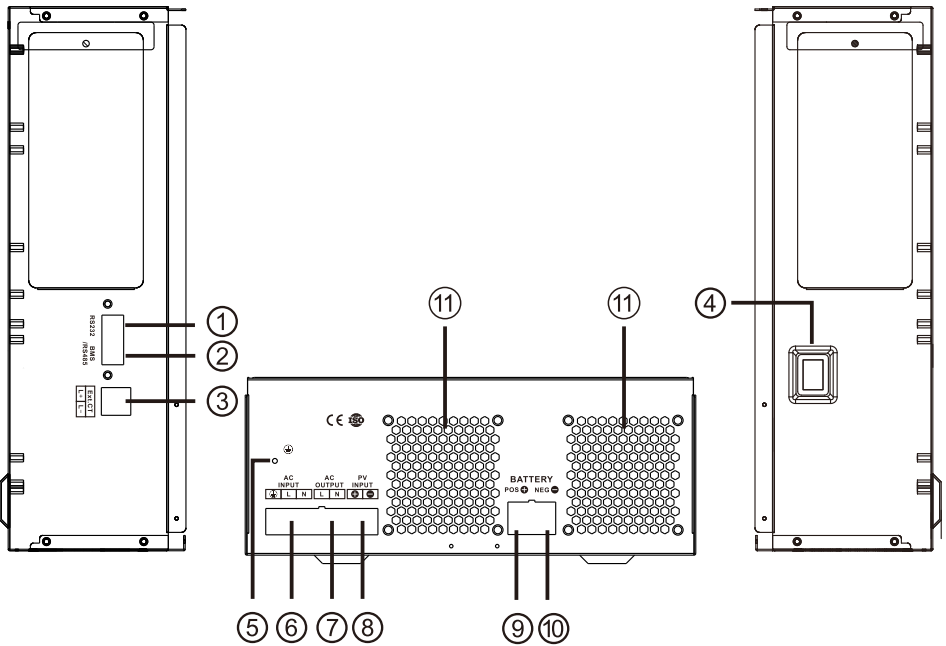

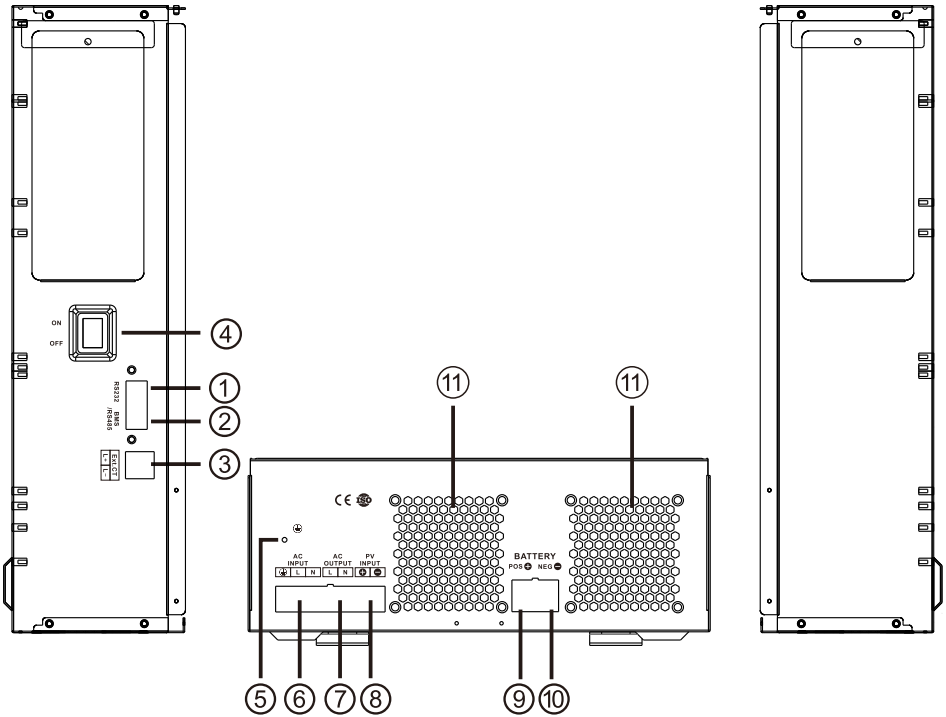

- | | |
|------------------------------------|---------------------------------|
| 1.....RS232 Communication Port | 7.....AC output |
| 2.....BMS/RS485 Communication Port | 8.....PV Input |
| 3.....CT Signal port | 9.....Battery Terminal Positive |
| 4.....Power ON/OFF Switch | 10...Battery Terminal Negative |
| 5.....Output ground wire | 11...Fan |
| 6.....AC Input | |

4 INSTALLATION

4.1 Unpacking and Inspection

Before installation, please inspect the unit. Be sure that nothing inside the package is damaged. You should have received the following items inside of package:

- ◆ The unit x 1
- ◆ User manual 1

4.2 Preparation

Before connecting all please take off bottom cover by removing two screws as shown below.

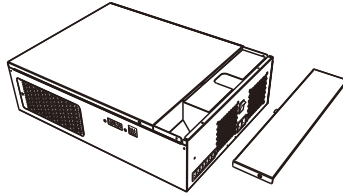

4.3 Mounting the Unit

Consider the following points before selecting where to install:

- ※ Do not mount the inverter on flammable construction materials.
- ※ Mount on a solid surface
- ※ Install this inverter at eye level in order to allow the LCD display to be read at all times.
- ※ For proper air circulation to dissipate heat, allow a clearance of approx. 20 cm to the side and approx. 50 cm above and below the unit.
- ※ The ambient temperature should be within the range of 20~35°C to ensure optimal operation
- ※ The recommended installation position is to be adhered to the wall vertically.
- ※ Be sure to keep other objects and surfaces as shown in the diagram to guarantee sufficient heat dissipation and to have enough space for removing wires.

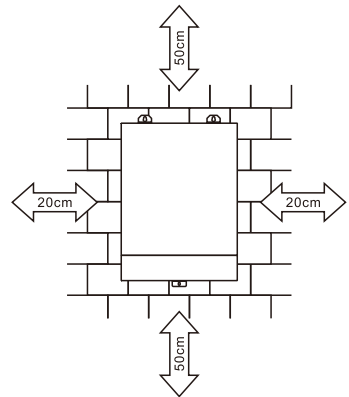

SUITABLE FOR MOUNTING ON CONCRETE OR OTHER NON-COMBUSTIBLE SURFACE ONLY.

Install the unit by screwing three screws.

- 1,2,3 Use the M6*80mm expansion bolts.

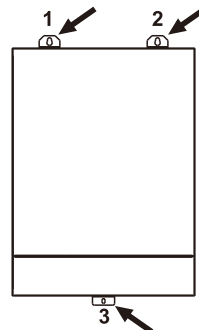

4.4 Battery Connection

CAUTION: For safety operation and regulation compliance, it's requested to install a separate DC over-current protector or disconnect device between battery and inverter. It may not be requested to have a disconnect device in some applications, however, it's still requested to over-current protection installed. Please refer to typical amperage in below table as required fuse or breaker size.

Ring terminal:

WARNING! All wiring must be performed by be qualified personnel.

WARNING! It's very important for system safety and efficient operation to use appropriate cable for battery connection. To reduce risk of injury, please use the proper recommended cable and terminal size as below.

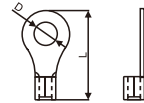

Recommended battery cable and terminal size:

Rated Capacity	Typical Amperage	Battery capacity	Wire Size	Ring Terminal			Torque value
				Cable(mm ²)	Dimensions		
					D(mm)	L(mm)	
2KVA	165A	200AH	2*4AWG	25	8.4	33.2	5Nm
3.6KVA	138A	200AH	2*4AWG	25	8.4	33.2	5Nm
6.2KVA	128A	200AH	1*2AWG	38	8.4	39.2	5Nm
			2*4AWG	25	8.4	33.2	
11KVA	228A	250AH	1*3/0AWG	85	8.4	54	5Nm

please follow below steps to implement battery connection:

1. Assemble battery ring terminal based on recommended battery cable and terminal size.

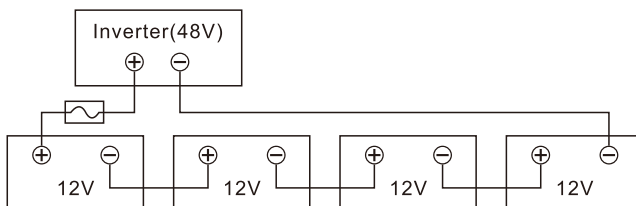
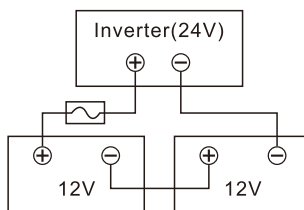

2. Insert the battery wires flatly into battery connectors of inverter and make sure the bolts are tightened with torque of 2 Nm in clockwise direction. Make sure polarity at both the battery and the inverter/charge is correctly connected and conductors are tightly screwed into the battery terminals. Recommended tool: # 2 Pozzi Screwdriver

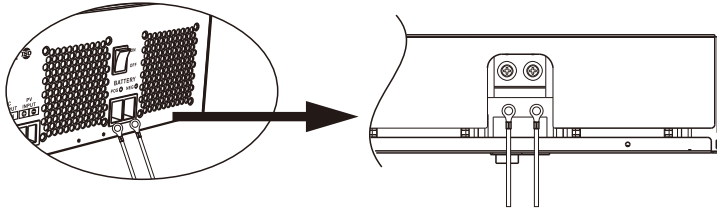

⚠ WARNING: Shock Hazard
Installation must be performed with care due to high battery voltage in series.

⚠ CAUTION!! Before making the final DC connection or closing DC breaker/disconnector, be sure positive (+) must be connected to positive (+) and negative (-) must be connected to negative (-).

4.5 AC Input Output Connection

CAUTION!! Before connecting to AC input power source, please Install a separate AC breaker between inverter and AC input power source. This will ensure the Inverter can be disconnected during maintenance and fully protected from over current of AC input. The recommended spec of breaker is 32A for 24V system and 63A for 48V system .

CAUTION!! There are two terminal blocks with " IN " and " OUT " markings. Please do NOT mis-connect input and output connectors.

WARNING! All wiring must be performed by qualified personnel.

WARNING! It's very important for system safety and efficient operation to use appropriate cable for AC input connection. To reduce risk of injury, please use the proper recommended cable size as below.

Suggested cable requirement for AC wires

Rated Capacity	Gauge	Torque value
2KVA	14AWG	0.8~1.0Nm
3.6KVA	12AWG	1.2~1.6Nm
6.2KVA	10AWG	1.4~1.6Nm
11KVA	8AWG	1.4~1.6Nm

Please follow below steps to implement AC input/ output connection

1. Before making AC input/output connection be sure to open DC protector or disconnector first.
2. Remove insulation sleeve 10mm for six conductors. And shorten phase L and neutral conductor N3 mm.

3. Insert AC input wires according to polarities indicated on terminal block and tighten the terminal screws. Be sure to connect PE protective conductor(⊕)first.

⊕→Ground(yellow-green)

L→LINE(brown or black)

N→Neutral (blue)

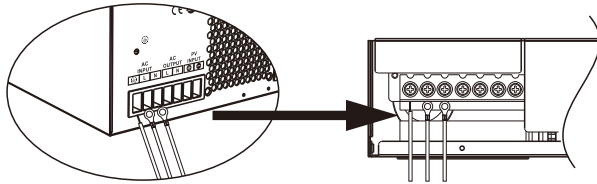

WARNING:

Be sure that AC power source is disconnected before attempting to hardwire it to the unit.

4. Make sure the wires are securely connected

CAUTION: Appliances such as air conditioner are required at least 2~3 minutes to restart because it's required to have enough time to balance refrigerant gas inside of circuits. If a power shortage occurs and recovers in a short time, it will cause damage to your connected appliances. To prevent this kind of damage, please check manufacturer of air conditioner if it's equipped with time-delay function before installation. Otherwise, this inverter/ charger will trig overload fault and cut off output to protect your appliance but sometimes it still causes internal damage to the air conditioner.

4.6 PV Connection

PV Connection(Only apply for the model with solar charger)

CAUTION:Before connecting to PV modules, please install **separately** a DC circuit breaker between inverter and PV modules.

WARNING! All wiring must be performed by a qualified personnel.

WARNING! It's very important for system safety and efficient operation to use appropriate cable for PV module connection. To reduce risk of injury, please use the proper recommended cable size as below.

Typical Amperage	Gauge	Torque Value
30A	12AWG	1.4~1.6Nm

PV module selection:

When choosing the right PV module, be sure to first consider the following requirements:

The open circuit voltage (Voc) of the PV modules does not exceed the maximum PV array open circuit voltage of the inverter. The maximum supply voltage of the PV modules should be close to the optimal PV access voltage range of the inverter for best performance. If one PV module cannot meet this requirement, it is necessary to connect multiple PV modules in series.

Model	DT1220SQ	DT2436SQ	DT4862SQ	DT4811SQ
PV Charging Mode	MPPT	MPPT	MPPT	MPPT Dual MPPT
MAX.PV Input Power	3000W	5000W	8500W	2*7500W
MPPT Tracking Range	60~500Vdc			90~500Vdc
Best Voltage	300-400V	300~400V	360~430V	360~430V
MAX.PV Input Voltage	500Vdc	500Vdc	500Vdc	500Vdc
PV Max Input Current	15A	15A	27A	27A/27A
MAX.PV Charging Current	100A	120A	120A	150A
MAX.AC Charging Current	80A	100A	100A	150A
MAX.Charging Current	100A	120A	120A	150A

PV Module Wire Connection

Please follow below steps to implement PV module connection:

1. Remove insulation sleeve 10 mm for positive and negative conductors.
2. Suggest to put bootlace ferrules on the end of positive and negative wires with a proper crimping tool
3. Fix wire cover to the inverter with supplied screws as shown in below chart.

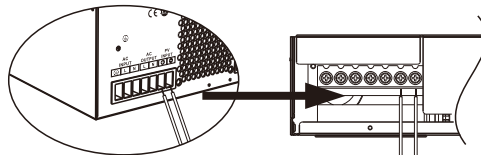
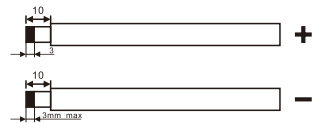

4. Check correct polarity of wire from PV modules and PV input connectors. Then, connect positive pole (+) of connection wire to positive pole (+) of PV input connector. Connect negative pole (-) of connection wire to negative pole (-) of PV input connector. Screw two wires tightly in clockwise direction. Recommended tool: 4mm blade screwdriver.

The CT Operation Guide

With CT connected, hybrid inverter can be easily integrated into the existing household system. It's to arrange self. consumption via CT to control power generation and battery charging of the Inverter.

1. Single commissioning

- Step 1.** Power off the inverter and connect the external CT by using the tool accessory to install on the spring terminal block. Be noted the mark of current flow direction on the CT should point to the Inverter and the polarity on connecting CT wires on the terminal block should be followed as "L+" VS red wire and "L-" VS black wire.

- Step 2.** Power on the inverter.

- Step 3.** Enter LCD setting on the inverter with CT sensor connected and set CT function to "PEC".

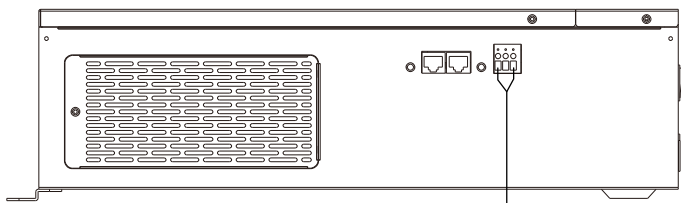

4.7 Final Assembly

After connecting all wirings, please put bottom cover back by screwing two screws as shown below.

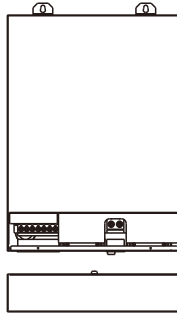

5 OPERATION

5.1 Power ON/OFF

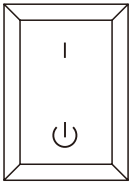

Once the unit has been properly installed and the batteries are connected well, simply press On/Off switch (located on the button of the case) to turn on the unit.

5.1.1 Steps to start up

Connect the battery that meets the requirements (battery voltage needs to be beyond 23V) or AC (AC needs to confirm the suitable input range depends on the output mode), then you can start up the inverter.

➤ Mains power on

Connect to normal AC power, press the switch, the system will automatically turn on. If you set AC output power priority, after waiting for a period of time, the panel will display AC mode that represents turn on the machine successfully, then will enter the AC mode.

When the normal mains power is connected and press the power-on button then the system will automatically power on. If it is set as AC output priority, after a period of time, the panel will display the AC mode to indicate that the power-on is complete and enter the AC mode.

➤ Battery boot

Connect to battery, press the power-on button to establish a working power source.

The system will automatically turn on, after waiting for a period of time, the panel will display battery mode that represents turn on the machine successfully, then will enter the battery mode.

5.1.2 Shutdown steps

When the system is in battery mode or AC mode output, press the switch again, then the system will be turned off.

5.2 Operation and Display Panel

The operation and display panel, shown in below chart , is on the front panel of the inverter. It includes three indicators , four function keys and a LCD display, indicating the operating status and input/output power information.

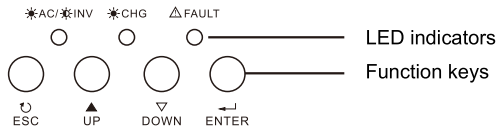
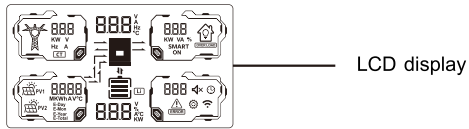

LED Indicator

LED Indicator		Messages	
☀ AC/☀ INV	Green	Solid On	Output is powered by utility in Line mode.
		Flashing	Output is powered by battery or PV in battery mode.
☀ CHG	Yellow	Solid On	Battery is fully charged.
		Flashing	Battery is charging.
⚠ FAULT	Red	Solid On	Fault occurs in the inverter.
		Flashing	Warning condition occurs in the inverter.

Function Keys

Function Key	Description
ESC	To exit setting mode
UP	To go to previous selection
DOWN	To go to next selection
ENTER	To confirm the selection in setting mode or enter setting mode

Display Setting

The LCD display information will be switched in turns by pressing "UP" or "DOWN" key. The selectable information is switched as below order: voltage, frequency, current, power, Temperature, firmware version, date.

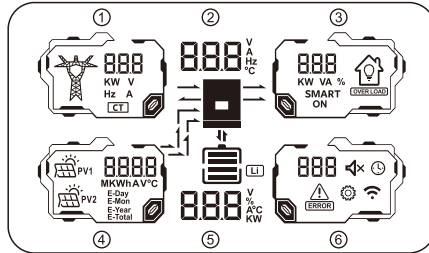

Select item	LCD display	
<p>① AC Input voltage (it indicates that the input voltage of the generator is displayed at this time, and the power and frequency displayed after turning the page are also the input parameters of the generator.)</p> <p>② Output voltage</p> <p>③ Load percentage</p> <p>④ Left:PV1 input voltage Right:PV2 input voltage</p> <p>⑤ Battery voltage</p> <p>⑥ Warning or Fault code(Default Display Screen)</p>		
<p>① AC Input frequency</p> <p>② Output frequency</p> <p>③ Load power in VA</p> <p>④ Left:PV1 input current Right: PV2 input current</p> <p>⑤ Battery current</p> <p>⑥ Warning or Fault code</p>		
<p>① AC input power in Watts</p> <p>② Output voltage</p> <p>③ Load power in Watts</p> <p>④ Left:PV1 input power in Watts Right:PV2 input power in Watts</p> <p>⑤ Battery in Watts</p> <p>⑥ Warning or Fault code</p>		

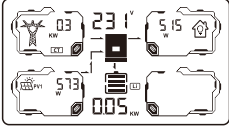
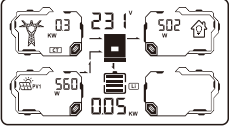
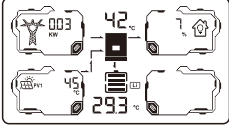
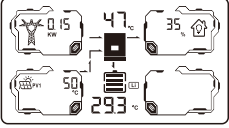
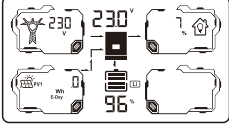
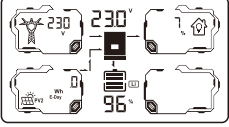
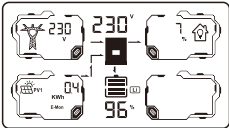
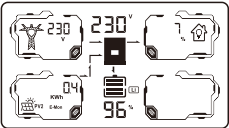
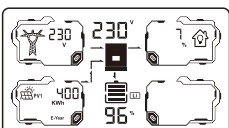
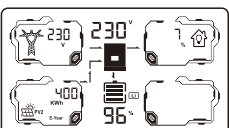
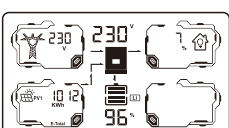
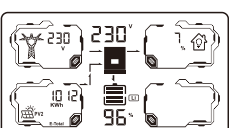
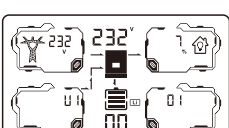
Select item	LCD display	
<ul style="list-style-type: none"> ① External CT AC input power in Watts (If the external CT is reversed, a "-" will be displayed in front of the power figure.) ② Output voltage ③ Apparent power ④ Left:PV1 input power in Watts Right:PV2 input power in Watts ⑤ Battery in Watts ⑥ Warning or Fault code 		
<ul style="list-style-type: none"> ① AC input power in Watts ② Inverter temperature ③ Load percentage ④ Left:PV1 temperature Right:PV2 temperature ⑤ Battery temperature ⑥ Warning or Fault code 		
<ul style="list-style-type: none"> ① AC Input voltage ② Output voltage ③ Load percentage ④ Left:PV1 energy generated this day /this Monthly/this year/total Right:PV2 energy generated this day /this Monthly/this year/total ⑤ Battery percentage ⑥ Warning or Fault code(Default Display Screen) 		
		
		
		
<p>Main board firmware version</p> <ul style="list-style-type: none"> ① AC Input voltage ② Output voltage ③ Load percentage ④⑤⑥ Firmware version (CPU:U1.00.01) 		

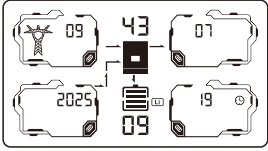
Select item	LCD display
① hour ② minute ③ second ④ year ⑤ month ⑥ day (09:43:07 September 19 2025)	

Operating Mode Description

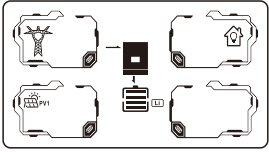
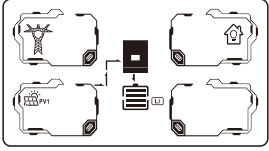
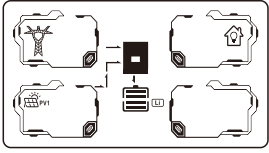
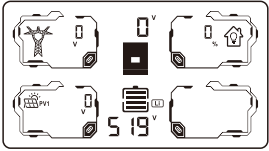
Operating mode	Behaviors	LCD display
<p>Standby mode</p> <p>Note:</p> <p>*Standby mode: The inverter is not turned on yet but at this time, the inverter can charge battery without AC output.</p> <p>*Power swing mode: If enabled, the output of inverter will be off when connected load is pretty low or not detected.</p>	<p>No output power, solar or utility charger available</p>	<p>Battery is charged by utility.</p> 
		<p>Battery is charged by PV energy.</p> 
		<p>Battery is charged by utility and PV energy.</p> 
		<p>No charging.</p> 

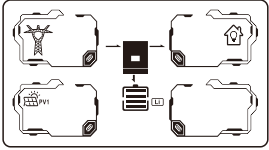
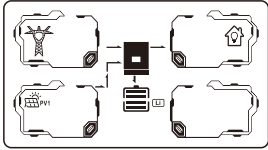
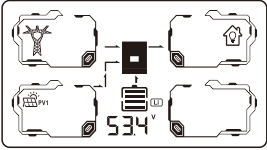
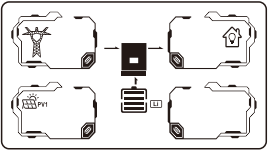
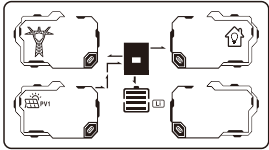
Operating mode	Behaviors	LCD display
Line mode	Output power from utility. Charger available	<p>Utility charges battery and provides power to load.</p> 
		<p>PV energy, battery power and utility provide power to load.</p> 
		<p>If "PEC"-is-selected as output source priority, PV energy and battery will support the output load with utility.</p> 
		<p>If "PEC" is selected as output source priority, Power from battery and utility.</p> 
		<p>If "SUF" is selected as output source priority, The remaining PV energy can be supplied to the grid.</p> 

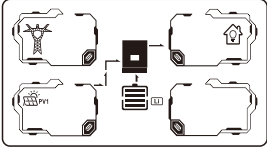
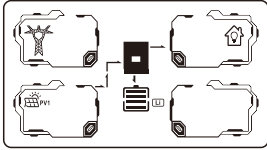
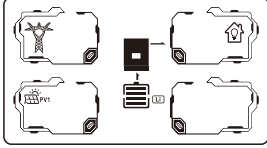
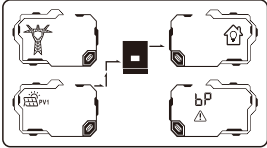
Operating mode	Behaviors	LCD display
Battery mode	Output power from battery or PV	<p>PV energy and battery energy supply power to the load.</p> 
		<p>The PV energy power to the load and has remaining energy to charge the battery</p> 
		<p>Battery provides power to the load.</p> 
Only PV mode	Output power from PV	<p>PV provides power to the load.</p> 

5.3 LCD Setting

After pressing and holding ENTER button for 3 seconds, the unit will enter setting mode. Press “UP” or “DOWN” button to select setting programs. And then, press “ENTER” button to confirm the selection or ESC button exit.

Setting Programs:

Program	Description	Selectable option	
00	Exit setting mode	Escape ESC 00	
01	Output source priority selection	Sub 01	Solar energy provides power to the loads as first priority. If solar energy is not sufficient to power all connected loads, Utility energy will supply power to the loads at the same time.
		Sbu 01	Solar energy provides power to the loads as first priority. If solar energy is not sufficient to power all connected loads, battery energy will supply power to the loads at the same time. Utility provides power to the loads only when battery voltage drops to either low-level warning voltage or the setting point in program 12 or solar and battery is not sufficient.
		SUF 01	If solar energy is sufficient to all connected loads and charge battery, the solar energy could feedback to the grid (sell power to grid). If solar energy is not sufficient to power all connected loads, Utility energy will supply power to the loads at the same time.
		PEC 01	The units will not only provide power to the connected load but also give power to connected home load. If PV power and battery power is insufficient, it will take grid energy as supplement. The units will not sell power to grid. In this mode, a CT can be used. The installation method of the CT please refer to chapter about CT connection. The external CT will detect power flowing back to the grid and will reduce the power of the inverter only to supply the local load, charge battery and home load.

02	Maximum charging current: To configure total charging current for solar and utility chargers. (Max. charging current = utility charging current + solar charging current)	60A(default) 60 ^A 02	Setting range is from 10A to maximum charging current. Increment of each click is 10A.
03	AC input voltage range	Appliances (default) APL 03	If selected, acceptable AC input voltage range will be within 90-280VAC.
		UPS UPS 03	If selected, acceptable AC input voltage range will be within 170-280VAC.
05	Battery type	AGM (default) AGM 05	Flooded FLD 05
		User-Defined USE 05	If "User-Defined" is selected, battery charge voltage, low DC cut-off voltage and dual cut -off voltage can be set up in program 24,26,27,29 and 61.
		LIA-protocol compatible battery LIA 05	
		Pylontech battery PYL 05	
		Techfine battery T9F 05	If selected, programs of 24,26,27 and 29 will be automatically set up. No need for further setting.
		Growatt battery GTO 05	
		Felicity battery FEL 05	
		LIB-protocol compatible battery LIB 05	Select "LIB if using Lithium battery compatible to Lib protocol. If selected, programs of 26,27 and 29 will be automatically set up. No need for further setting.
		3 rd party lithium battery LIC 05	If selected, programs of 26,27 and 29 will be automatically set up. No need for further setting. Please contact the battery supplier for installation procedure.

06	Auto restart when overload occurs	Restart disable(default) EEd 06	Restart enable LEE 06
07	Auto restart when over temperature occurs	Restart disable (default) EEd 07	Restart enable LEE 07
08	ECO function: System will temporarily stop when the load is low in battery mode.	disable (default) ECO 5d5 08	
		enable ECO 5e7 08	
09	Output frequency	50Hz(default) 50 ^{Hz} 09	60Hz 60 ^{Hz} 09
10	Output voltage	220V 220 ^v 10	230V (default) 230 ^v 10
		240V 240 ^v 10	
11	Maximum utility charging current Note: If setting value in program 02 is smaller than that in program in 11, the inverter will apply charging current from program 02 for utility charger.	30A(default) 30A 11	Setting range is 2A, then from 10A to max.AC charging current. Increment of each click is 10A.
12	Setting voltage point back to utility source when selecting "SBU priority" in program 01.	Available options in 24 system model:	
		23.0V (default) 230 ^v 12	Setting range is from 22V to 25.5V. Increment of each click is 0.5V.
		Available options in 48 system model:	
		46V (default) 460 ^v 12	Setting range is from 44V to 51V. Increment of each click is 1V.

13	Setting voltage point back to battery mode when selecting "SBU priority" in program 01.	Available options in 24 system model:	
		Battery fully charged	27V(default)
		FUL 13	270 ^v 13
		Setting range is from 24V to 29V. Increment of each click is 0.5V.	
		Available options in 48 system model:	
		Battery fully charged	54V (default)
FUL 13	540 ^v 13		
Setting range is from 48V to 58V. Increment of each click is 1V.			
16	Charger source priorit: To configure charger source priority	If this inverter/charger is working in Line, Standby or Fault mode, charger source can be programmed as below:	
		Solar first	Solar energy will charge battery as first priority. Utility will charge battery only when solar energy is not available.
		C50 16	
		Solar and Utility(default)	Solar energy and utility will charge battery at the same time.
		5NU 16	
		Only Solar	Solar energy will be the only charger source no matter utility is available or not.
050 16			
Solar residual	Solar energy will support all connected loads as first priority, the residual energy will charge battery		
5ot 16			
If this inverter/charger is working in Battery mode, only solar energy can charge battery. Solar energy will charge battery if it's available and sufficient.			
17	Battery reboot voltage	default: H4 535 ^v 17	If in SOC mode, when the machine will restart and resume operation until the PV charging reaches the set value after the battery is low and the device shuts down.
18	Alarm control	Alarm on (default) 60N 18	Alarm off 60F 18

19	Auto return to default display screen	Return to default display screen (default) ESP 19	If selected, no matter how users switch display screen, it will automatically return to default display screen (Input voltage /output voltage) after no button is pressed for 1 minute.
		Stay at latest screen FEP 19	If selected, the display screen will stay at latest screen user finally switches.
20	Backlight control	Backlight on (default) LON 20	Backlight off LOF 20
22	Beeps while primary source is interrupted	Alarm on (default) RON 22	Alarm off ROF 22
23	Overload bypass: When enabled, the unit will transfer to line mode if overload occurs in battery mode.	Bypass disable (default) byd 23	Bypass enable byE 23
24	Battery low voltage ● If battery power is only power source available inverter will alarm.	Battery low voltage 44.0V LOV 44.0 ^v 24	
		Setting range is from 20.0V-27.0V for 24V system and 40.0V-54.0V for 48V system.	
25	Record fault code	Record enable (default) FEN 25	Record disable FBS 25
		24V system default setting:28.2V CV 28.2 ^v 26	
26	Bulk charging voltage (C.V voltage)	48V system default setting:56.4V CV 56.4 ^v 26	
		If self-defined is selected in program 5, this program can be set up. Setting range is from 24.0V to 30.0V for 24V system and 48.0V to 60.0V for 48V system. Increment of each click is 0.1V.	
		24V system default setting:27.0V FLV 27.0 ^v 27	
27	Floating charging voltage	48V system default setting:54.0V FLV 54.0 ^v 27	

28	Reset factory setting	default: Std OFF 28	
		Std ON 28	
29	Low DC cut-off voltage: <ul style="list-style-type: none"> • If battery power is only power source available inverter will shut down. • If PV energy and battery power are available, inverter will charge battery without AC output. 	24V system default setting:21.0V COV 210 ^v 29	
		48V system default setting:42.0V COV 420 ^v 29	
		If self-defined is selected in program 5, this program can be set up. Setting range is from 20.0V to 26.0V for 24V system and 40.0V to 52.0V for 48V system. Increment of each click is 0.1V Low DC cut-off voltage will be fixed to setting value no matter what percentage of load is connected.	
30	Battery equalization	Battery equalization EEN 30	Battery equalization disable (default) Ed5 30
		If "Flooded" or "User Defined" is selected in program 05, this program can be set up.	
31	Battery equalization voltage	24V system default setting:29.2V EV 292 ^v 31	
		48V system default setting:58.4V EV 584 ^v 31	
		Setting range is from 24.0V to 30.0V for 24V system and 48.0V to 60.0V for 48V system. Increment of each click is 0.1V.	
33	Battery equalized time	60min (default) 60 33	Setting range is from 5min to 900min. Increment of each click is 5min.
34	Battery equalized timeout	120min (default) 120 34	Setting range is from 5min to 900min. Increment of each click is 5min.
35	Equalization interval	30days (default) 30d 35	Setting range is from 0 to 90 days. Increment of each click is 1 day.

		Enable	Disable (default)
36	Equalization activated immediately	AEQ 36	AdS 36
		If equalization function is enabled in program 30, this program can be set up. If "Enable" is selected in this program, it's to activate battery equalization immediately and LCD main page will shows "EQ", If "Disable" is selected, it will cancel equalization function until next activated equalization time arrives based on program 35 setting. At this time, "EQ" will not be shown in LCD main page.	
37	BMS Function Switch	off(default) bns OFF 37	Whether to enable the BMS communication function
		bns ON 37	
38	Bat Soc Under Lock	bSU 10% 38	If any type of lithium battery is selected in program 5. BMS low voltage SOC value, if the BMS SOC value is lower than the set value, the inverter will shut down to protect the battery.
39	Bat Soc Turn To Ac	StC 20% 39	If any type of lithium battery is selected in program 5. When the working mode of the inverter is set to the battery priority mode, the inverter will be forced to enter the mains charging when the SOC of the BMS is lower than the set value.
40	Bat Soc Turn To Dc	Stb 95% 40	If any type of lithium battery is selected in program 5. When the working mode of the inverter is set to the battery priority mode, the inverter resumes the DC working mode when the SOC of the BMS is higher than the set value.
41	Bat Restart Soc	bSt 50% 41	If any type of lithium battery is selected in program 5. When the inverter is turned on, the SOC must be higher than the set value to work normally.
45	Reset PV energy storage	Notre set (Default) nrE 45	Reset rSt 45
46	Start charging time for AC charger	00:00(Default) StA 000# 46	The setting range of start charging time for AC charger is from 00:00 to 23:00, increment of each click is 1 hour.
47	Stop charging time for AC charger	00:00(Default) StO 000# 47	The setting range of scheduled Time for AC output on is from 00:00 to 23:00, increment of each click is 1 hour.

48	Scheduled time for AC output on	00:00(Default) 00 00 48 The setting range of scheduled Time for AC output on is from 00:00 to 23:00, increment of each click is 1 hour.	
49	Scheduled time for AC output off	00:00(Default) OFF 00 49 The setting range of scheduled Time for AC output off is from 00:00 to 23:00, increment of each click is 1 hour.	
50	Set country customized regulations	Mode 1 IND 50	If selected, acceptable feed-in grid voltage range will be 195.5-253VAC. Acceptable feed-in grid frequency range will be 49-51Hz.
		Mode 2 GER 50	If selected, acceptable feed-in grid voltage range will be 184-264.5VAC. Acceptable feed-in grid frequency range will be 47.5-51.5Hz.
		Mode 3 SRD 50	If selected, acceptable feed-in grid voltage range will be 184-264.5VAC. Acceptable feed-in grid frequency range will be 57-62Hz.
		Mode 4 PAT 50	If selected, acceptable feed-in grid voltage range will be 170-264.5VAC. Acceptable feed-in grid frequency range will be 47.5-53.5Hz.
		Mode 5(Default) U26 50	If selected, acceptable feed-in grid voltage range will be 100-280VAC. Acceptable feed-in grid frequency range will be 47.5-53.5Hz.
51	Time setting-Minute	For minute setting, the range is from 00 to 59. 00 00 51	
52	Time setting-Hour	For hour setting, the range is from 00 to 23. HOU 00 52	
53	Time setting-Day	For day setting, the range is from 00 to 31. dAt 01 53	
54	Time setting-Month	For month setting, the range is from 1 to 12 mOn 01 54	
55	Time setting-Year	For year setting, the range is from 16 to 99. YEA 16 55	
56	GRID-tie power	6.2KW 6.2 _{kw} 56	Increment of each click is 200W.

58	Set the input power of the mains power	0.15KW(default) 2EP 0.15 _{kw} 58	Setting range is from 0.01KW to 0.5KW. Increment of each click is 0.01KW.
59	Max battery discharge current setting	200(default) d IC 200 59	When the battery discharge current more than the setting value, the unit will be alarm. The setting range is from 20 to 200.
67	Output Open Time	d t A 000 67	The value ranges from 0 to 23.
68	Output Stop Time	d t 0 000 68	The value ranges from 0 to 23.
71	Start time setting for power grid peak shaving	00:00(Default) L S A 000 71	In PEC mode, set the start time and stop time for the battery to sell electricity according to requirements.
72	Stop time setting for power grid peak shaving	00:00(Default) L S 0 000 72	

When the BMS/485 communication interface is externally connected, as shown in the following figure:

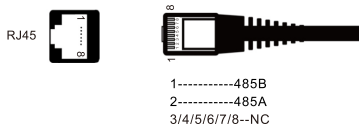

Communication Connection

Please use supplied communication cable to connect to inverter and PC. Please install a monitoring software on the computer.

5.4 Battery Equalization Description

Equalization function is added into charge controller, It reverses the buildup of negative chemical effects like stratification, a condition where acid concentration is greater at the bottom of the battery than at the top. Equalization also helps to remove sulfate crystals that might have built up on the plates. If left unchecked, this condition, called sulfation, will reduce the overall capacity of the battery. Therefore, it's recommended to equalize battery periodically.

※ **How to Apply Equalization Function**

You must enable battery equalization function in monitoring LCD setting program 30 first. Then, you may apply this function in device by either one of following methods:

1. Setting equalization interval in program 35.
2. Active equalization immediately in program 36.

※ **When to Equalize**

In stage, when the setting equalization interval(battery equalization cycle) is arrived, or equalization is active immediately, the controller will start to enter Equalize stage.

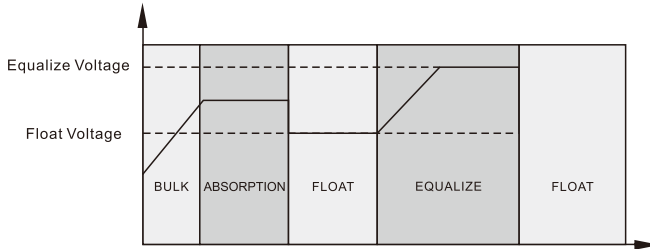

※ **Equalize charging time and timeout**

In Equalize stage, the controller will supply power to charge battery as much as possible until battery voltage raises to battery equalization voltage. Then, constant-voltage regulation is applied to maintain battery voltage at the battery equalization voltage. The battery will remain in the Equalize stage until setting battery equalized time is arrived.

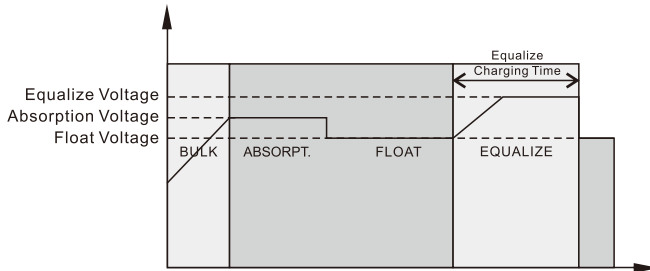

However, in Equalize stage, when battery equalized time is expired and battery voltage doesn't rise to battery equalization voltage point, the charge controller will extend the battery equalized time until battery voltage achieves battery equalization voltage. If battery voltage is still lower than battery equalization voltage when battery equalized timeout setting is over, the charge controller will stop equalization and return to float stage.

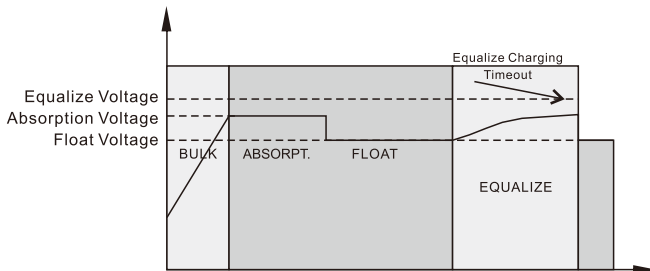

5.5 Fault and alarm description

5.5.1 Faults Descriptions

➤ **Fault:** The inverter enters the fault mode, the red LED light is always on and the LCD displays the fault code.

Fault Reference Code

Fault Code	Fault Event	Icon on
F01	Fan is locked when inverter is off.	F01 <small>ERROR</small>
F02	Over temperature or NTC is not connected well.	F02 <small>ERROR</small>
F03	Battery voltage is too high.	F03 <small>ERROR</small>
F04	Battery voltage is too low.	F04 <small>ERROR</small>
F05	Output short circuited or over temperature is detected by internal converter components.	F05 <small>ERROR</small>
F06	Output voltage is too high.	F06 <small>ERROR</small>
F07	Over load time out.	F07 <small>ERROR</small>
F08	Bus voltage is too high	F08 <small>ERROR</small>
F09	Bus soft start failed	F09 <small>ERROR</small>
F51	Over currents or urge	F51 <small>ERROR</small>
F52	Bus voltage is too low	F52 <small>ERROR</small>
F53	Inverter soft start failed	F53 <small>ERROR</small>
F55	Over DC voltage in AC output	F55 <small>ERROR</small>
F57	Current sensor failed	F57 <small>ERROR</small>
F58	Output voltage is too low	F58 <small>ERROR</small>
F59	PV voltage is over limitation	F59 <small>ERROR</small>

5.5.2 Alarm Descriptions

➤ **Alarm:** The red LED flashes, and the LCD displays an alarm code, the inverter does not enter the failure mode

Alarm Indicator

Alarm Code	Alarm Event	Audible Alarm	Icon flashing
A01	Fan is locked when inverter is on.	Beep three times every second	A01 ⚠
A02	Over temperature	None	A02 ⚠
A03	Battery is over-charged	Beep once every second	A03 ⚠
A04	Low battery	Beep once every second	A04 ⚠
A07	Overload	Beep once every 0.5 second	A07 ⚠
A10	Output power derating	Beep twice every 3 seconds	A10 ⚠
A15	PV energy is low.	Beep twice every 3 seconds	A15 ⚠
A16	High AC input (>280VAC) during BUS soft start	None	A16 ⚠
A27	Max battery discharge current setting	None	A27 ⚠
E9	Battery equalization	None	E9 ⚠
bP	Battery is not connected	None	 bP ⚠

5.5.3 Code Reference

Related information code will be displayed on LCD screen. Please check inverter LCD screen for the operation.

Code	Description
60 ⚠	If battery status is not allowed to charge and discharge after the communication between the inverter and battery is successful, it will show code 60 to stop charging and discharging battery.
61 ⚠	Communication lost <ul style="list-style-type: none"> After battery is connected, communication signal is not detected for 1 minutes, buzzer will beep. Communication lost occurs after the inverter and battery is connected successfully, buzzer beeps immediately.
69 ⚠	If battery status is not allowed to charge after the communication between the inverter and battery is successful, it will show code 69 to stop charging battery.
70 ⚠	If battery status must to charge after the communication between the inverter and battery is successful, it will show code 70 to charge battery.
71 ⚠	If battery status is not allowed to discharge after the communication between the inverter and battery is successful, it will show code 71 to stop discharge battery.

6. Trouble removal

Problem	LCD/LED/Buzzer	Explanation/Possible cause	What to do
Unit shuts down automatically during startup process.	LCD/LEDs and buzzer will be active for 3 seconds and then complete off.	The battery voltage is too low (<1.91V/Cell)	1. Re-charge battery. 2. Replace battery.
No response after power on.	No indication.	1. The battery voltage is far too low.(<1.4V/Cell) 2. Internal fuse tripped.	1.Contact repair center for replacing the fuse. 2. Re-charge battery. 3. Replace battery. Check if AC breaker is tripped and AC wiring is connected well.
Mains exist but the unit works in battery mode.	Input voltage is displayed as 0 on the LCD and green LED is flashing.	Input protector is tripped	1. Check if AC wires are too thin and/or too long. 2. Check if generator (if applied)is working well or if input voltage range setting is correct.(UP-->sppliance)
	Green LED is flashing	Insufficient quality of AC power. (Shore or Generator)	1. Check if AC wires are too thin and/or too long. 2. Check if generator (if applied)is working well or if input voltage range setting is correct.(UP-->sppliance)
	Green LED is flashing.	Set "Solar First" as the priority of output source.	Change output source priority to Utility first.
When the unit is turned on, internal relay is switched on and off repeatedly.	LCD display and LEDs are flashing	Battery is disconnected.	Check if battery wires are connected well.
Buzzer beeps continuously and red LED is on.	Fault code 07	Overload error. The inverter is overload 105% and time is up.	Reduce the connected load by switching off some equipment.
		If PV input voltage is higher than specification, the output power will be derated.At this time, if connected loads is higher than derated output power, it will cause overload.	Reduce the number of PV modules in series or the connected load.
	Fault code 05	Output short circuited.	Check if wiring is connected well and remove abnormal load.
		Temperature internal converter component is over 120°C.	Check whether the air flow of the unit is blocked or whether the ambient temperature is too high.
	Fault code 02	Internal temperature of inverter component is over 100°C	Return to repair center.
	Fault code 03	Battery is over-charged	Return to repair center.
		The battery voltage is too high.	Check if spec and quantity of batteries are meet requirements.
	Fault code 01	Fan fault	Replace the fan.
	Fault code 06/58	Output abnormal (Inverter voltage below than 190Vac or is higher than 260Vac)	1. Reduce the connected load. 2. Return to repair center
	Fault code 08/09/53/57	Internal components failed.	Return to repair center.
	Fault code 51	Over current or surge.	Restart the unit, if the error happens again, please return to repair center.
Fault code 52	Bus voltage is too low.		
Fault code 55	Output voltage is unbalanced.		
Fault code 59	PV input voltage is beyond the specification.	Reduce the number of PV modules in series.	

7. Technical datasheet

Model		DT1220SQ	DT2436SQ	DT4862SQ	DT4811SQ	
Input	Input Sources	L+N+PE				
	Rated Input Voltage	220/230/240VAC				
	Voltage Range	90-280VAC±3V(APL Mode)170-280VAC±3V(UPS Mode)				
	Frequency	50Hz/60Hz(Auto Adaptive)				
Output	Rated power	The battery inverts	1600W	3600W	6200W	11000W
		Photovoltaic inverter	2000W	3600W	6200W	12000W
	Output Voltage	220/230/240VAC±5%				
	Output Frequency	50/60Hz±0.1%				
	Waveform	Pure Sine Wave				
	Transfer Time (adjustable)	Computers(UPS Mode)10ms, Appliance(APL Mode)20ms				
	Peak Power	3200VA	7200VA	12400VA	22000VA	
	Overload capacity	Battery mode:11s@105%~150% Load;2s@150%~200% Load; 400ms@>200% Load				
Grid-connected operation	Output Voltage	220/230/240VAC±5%				
	Feed into the grid voltage range	100-280VAC				
	Feed into the grid frequency range	47~53±1Hz/57~62±1Hz				
	Nominal output current	8.7A	15.7A	26.9A	47.8A	
	Power Factor Range	>0.99				
	Maximum conversion efficiency(DC/AC)	98%				
Battery	Battery Voltage	12Vdc	24Vdc	48Vdc	48Vdc	
	Constant Charging Voltage (Adjustable)	14.1Vdc	28.2Vdc	56.4Vdc	56.4Vdc	
	Floate Charging Voltage (Adjustable)	13.5Vdc	27Vdc	54Vdc	54Vdc	
Chargers	PV Charging Mode	MPPT	MPPT	MPPT	MPPT Dual MPPT	
	MAX.PV Input Power	3000W	5000W	8500W	2*7500W	
	MPPT Tracking Range	60~500Vdc			90~500Vdc	
	Best voltage	300-400V	300-400V	360-430V	360-430V	
	MAX.PV Input Voltage	500Vdc	500Vdc	500Vdc	500Vdc	
	PV Max Input Current	15A	15A	27A	27A/27A	
	MAX.PV Charging Current	100A	120A	120A	150A	
	MAX.AC Charging Current	80A	100A	100A	150A	
MAX.Charging Current	100A	120A	120A	150A		
Display	LCD interface	CAN display running mode/load/input/output,etc.				
Interface	RS232	Baud Rate2400				
	Extend the socket communication interface	Lithium Battery BMS Communication Card WifiCard				
Environments	Operating Temperature	-10~50℃				
	Humidity	20%~95%(Non-condensing)				
	Storage Temperature	-15~60℃				
	Altitude	Altitude Not Over 1000m,Derating over 1000m,Max 4000m, Refer to IEC62040				
	Noise	≤50db				
Standards and certification		EN-IEC 60335-1,EN IEC 60335-2-29, IEC 62109-1				