

USER MANUAL

Solar Battery Pack

MF-48314S

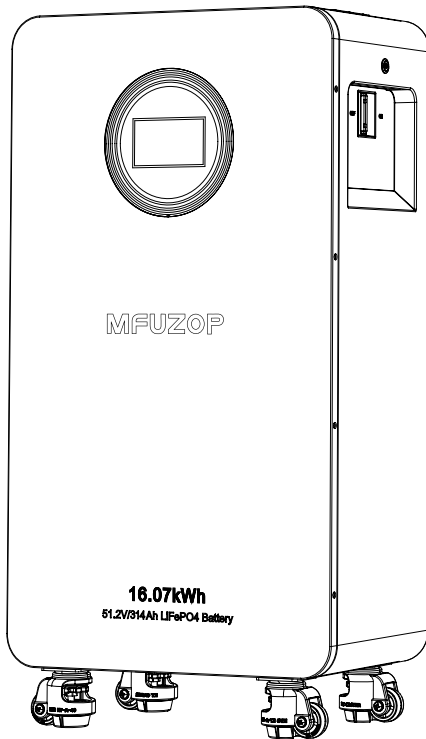

1. Usage Safety Instructions

Please keep this manual properly for future reference. It details the installation and operation standards for the solar product pack. Before installation or use, be sure to read all instructions and precautions carefully.

1.1 Safety Warnings

There are non-safe voltages inside the solar product pack, and it is strictly prohibited for users to disassemble it privately. In case of equipment failure and need for maintenance, please contact professional maintenance personnel in time.

1.2 Precautions for Use

1. Avoid immersion of the product in water or exposure to moisture.
2. Prohibit charging the product near fire sources and in high-temperature environments, and avoid using or storing the product near heat sources such as heaters.
3. If leakage or abnormal odor is detected, immediately transfer the product to a safe, open area.
4. Use the designated charging cable; if replacement is needed, ensure it matches the original wire gauge.
5. Pay attention to the correct polarity during installation; do not connect in reverse.
6. Do not connect the product directly to wall sockets or car cigarette lighter sockets.
7. Do not place the product in a fire or heat it.
8. Avoid using wires or other metal objects to short-circuit the product terminals. Do not transport or store the product along with necklaces, hairpins, or other metal objects.
9. Do not pierce the product with nails or sharp objects, and do not strike or step on the product.
10. Avoid impacts, throwing, or other mechanical shocks.
11. Do not weld directly onto the product terminals.
12. Do not disassemble the product by any method.
13. Do not mix this product with original products (such as dry cells), or with different capacities, models, or types.
14. If the product has been left unused in storage for more than 3 months, perform recharging.

1.3 Abnormal Situations

1. If leakage or odor is detected, immediately move the product to an open and safe area. If the electrolyte comes into contact with your eyes, do not rub, flush with plenty of water and seek medical attention immediately.
2. If the product is hot, deformed, discolored or has other abnormalities, please stop using it, and if it is charging/discharging, remove the product immediately.
3. If the product smokes or catches fire, please ensure your own safety and quickly move the product to a fireproof and open place (e.g., sand, metal container).

1.4 Environmental Tips

Discharged batteries should be recycled according to local regulations. Do not dispose of them at will.

2 Installation Instructions

2.1 Unpacking and inspection

Inspect the unit before installation. Make sure there is no damage in the package. You should receive the following items in the package:

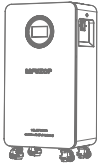

Solar Battery Pack x1

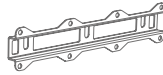

Mounting Bracket x1



Short Screws x3



Short Screws x2



Expansion Screws x8



User Manual x1

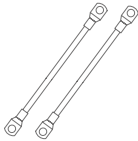

Positive and Negative Leads x1



Communication Cable x1



Host Computer
Communication Cable x1

2.2 Preparator work (installation in the of state, it is recommended that the installation of equipment to find a professional electrician installation)

Wall-mounted Before selecting a mounting location, consider the following points:

- ① . Do not install the all-in-one on flammable building materials.
- ② . Do not install the product in a harsh environment.
- ③ . Mounted on a sturdy surface.
- ④ . Install the All-in-One at eye level so that the LCD display can be read at all times.
- ⑤ . The ambient temperature should be between 0°C and 55°C to ensure optimal operation.

- ⑥ . Vertical mounting on the wall is recommended.
- ⑦ . Be sure to retain the other objects and suraces shown at right to allow for adequate heat dissipation and enough room to remove the wires.
- ⑧ . Before connecting all wiring, remove the bottom cover by unscrewing the two screws as shown below.



WARNING !

Requires the product to be installed with the power off and disconnected.

2.3 Installation Steps

Wall-mounted Before selecting a mounting location, consider the following points:

- ① . Check that all wires are wired as specified.
- ② . Before using the product, it must be used in accordance with the requirements of the parameters within the manual.

Note: that the air switch is in the "ON" state, then press the key to turn on the product, the product can be used normally.

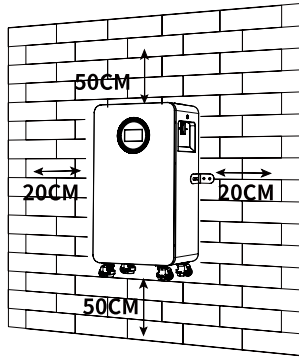

- Requires the product to be installed with the power off and disconnected.
- All wiring work must be carried out by qualified personnel.

3. Specification

Total Energy	16.07 KWh
Internal Resistance	≤13.9mΩ
Single Battery Capacity	314Ah
Nominal Operating Voltage	51.2V
Standard Input Current	150A (200A Max)
Standard Output Current	200A
Overpressure Protection	58.4V
Overcharge Protection Recovery	54.0V
Over-discharge Protection	43.2V
Over-discharge Protection Recovery	46.4V
High-temperature Charging Protection	60°C
High-temperature Charging Recovery	55°C
Low-temperature Charging Protection	0°C
Low-temperature Charging Recovery	5°C
High-temperature Discharge Protection	60°C
High-temperature Discharge Recovery	55°C
Low-temperature Discharge Protection	-20°C
Low-temperature Discharge Recovery	-15°C
Overcurrent Protection (Charging)	215A
Overcurrent Protection (Discharging)	215A
Short Circuit Protection	Yes, method via "load removal and charge disconnection"
Power Delivery Rate	40% to 60%
Equalization	Passive balancing
Power Consumption when Off	≤300μA
Cycle Life	≥8000 Cycle , 70% SOH 25°C
	≥3000 Cycle , 70% SOH 45°C
Protection Level	IP20
Communication Protocols	RS232, RS485, CAN
Dimensions (L×W×H)	453×260×879 mm
Weight	113 kg

4. Function Introduction

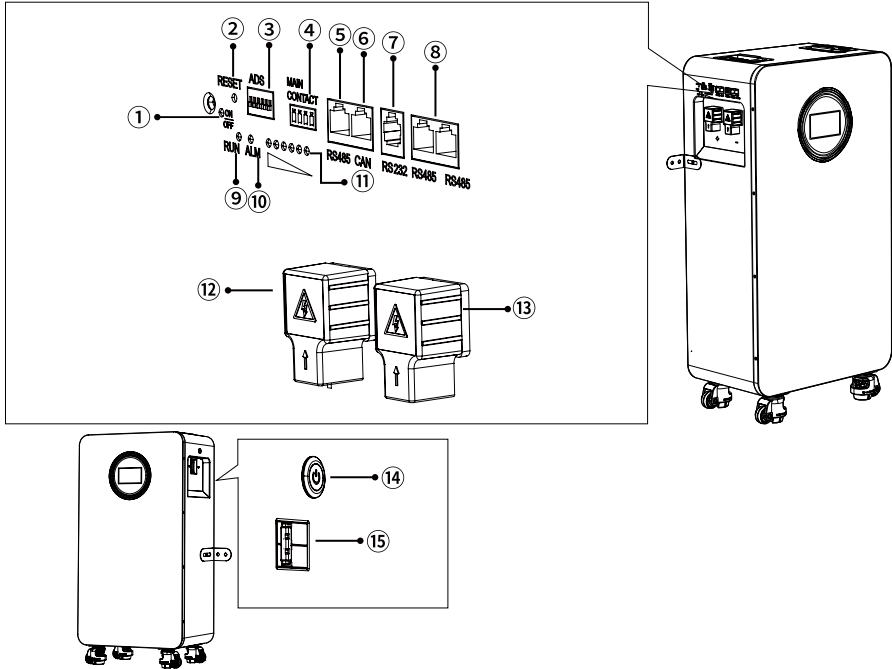

Number	Functionality	Descriptive
①	Switch Indicator Lights	Switch Status
②	Reset switch	Reboot or shutdown when pressed
③	DIP Address	Parallel or communication address selection
④	Dry contact	Normally open or normally closed signal driven relay
⑤	RS485	For connecting inverters
⑥	CAN	For connecting inverters
⑦	RS232	for upper computer
⑧	RS485-1&RS485-2	for upper computer or battery parallel
⑨	Operation Indicator	Operational status
⑩	Alarm Indicator	Alarms
⑪	Battery indicator	Battery level indication
⑫	Battery Positive	Battery Positive
⑬	Battery Negative	Battery negative
⑭	Mains Switch	Control switch
⑮	Air switch	Disconnect input and output

4.1 Table 1 LED Indicator Description

Table 1 LED Indicator Description

Status	Item	ON/OFF LED9	RUN (LED8)	ALARM (LED7)	SOC(LED6~1)	Description		
		●	●	●	●●●●●●●			
Power Off	Sleep Mode	OFF	OFF	OFF	OFF	All LEDs off		
Static state	Normal	ON	Flash 1	OFF	Refer to Table 2	/		
	Alarm	ON	Flash 1	Flash 3				
Charging	Normal	OFF	OFF	OFF		Refer to Table 2	Over-voltage alarm, no blinking	
	Alarm	ON	ON	Flash 3				
	OV protect	ON	ON	OFF				ON
	Temperature, Over-current, fail-safe)	ON	OFF	ON				OFF
Discharging	Normal	ON	Flash 3	OFF	Refer to Table 2	/		
	Alarm	ON	Flash 3	Flash 3				
	UV Protection	OFF	Flash 2	OFF			OFF	
	Overcurrent, Short Circuit, Temperature, Fault Safety	ON	OFF	ON			OFF	

Table 2 SOC Indicator Description

State		Charging					Discharging						
LED		LED6	LED5	LED4	LED3	LED2	LED1	LED6	LED5	LED4	LED3	LED2	LED1
SOC(%)	0~16.6%	OFF	OFF	OFF	OFF	OFF	Flash 2	OFF	OFF	OFF	OFF	OFF	ON
	16.6~33.2%	OFF	OFF	OFF	OFF	Flash 2	ON	OFF	OFF	OFF	OFF	ON	ON
	33.2~49.8%	OFF	OFF	OFF	Flash 2	ON	ON	OFF	OFF	OFF	ON	ON	ON
	49.8~66.4%	OFF	OFF	Flash 2	ON	ON	ON	OFF	OFF	ON	ON	ON	ON
	66.4~83.0%	OFF	Flash 2	ON	ON	ON	ON	OFF	ON	ON	ON	ON	ON
	83.0~100%	Flash 2	ON	ON	ON	ON	ON	ON	ON	ON	ON	ON	ON
RUN LED ●		ON					Flash 3						

Table 3 LED flash description

Mode	ON	OFF
Flash 1	0.25S	3.75S
Flash 2	0.5S	0.5S
Flash 3	0.5S	1.5S

4.2 Description of Buzzer Action

- ① . When a fault occurs, a 0.25S signal is emitted every 1 second.
- ② . During protection, a 0.25S horn is emitted every 2 seconds (except for overpressure and underpressure protection).
- ③ . When an alarm is issued, a 0.25S alarm is emitted every 3 seconds (except for overpressure or underpressure alarms).

4.3 Reset Switch Description

Corresponding icon:



- ① . When the BMS is in sleep mode, press the switch (1S) to turn it off, and the protection board is activated. The LED indicator will light up for 0.5 seconds.
- ② . When the BMS is active, press the switch (3 to 6 seconds), and the LED indicator will light up from the minimum power indicator to maximum power indicator for 0.5 seconds. After turning off, the system will enter sleep mode.
- ③ . When the BMS is active, press the button (6-10 seconds) and release to reset the board. The LED indicator will reflect the current power display.

4.4 Mains Switch Instructions

Corresponding icon:

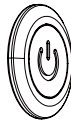

- ① . When the BMS is in hibernation state, after turning off the main switch, the protection board is energized, and the LEDs are lit sequentially starting from "LED1" for 0.5 seconds.
- ② . When BMS is active, turn off the main switch and wait for 1S~3S, then the system will enter the power-off state.

4.5 Dip Switch

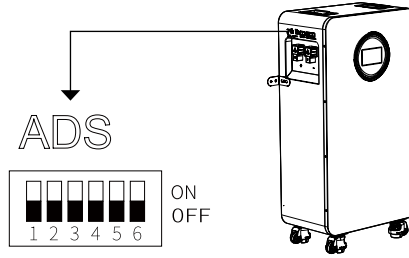

When connecting battery packs in parallel, use the DIP switch on the BMS to set the address to distinguish different data packets. The maximum number of parallel units is 15, of which 5 and 6 are reserved and have no function.

Address bit (binary)	Explain				
	4	3	2	1	
0001(1)	OFF	OFF	OFF	ON	Set PACK1 to be used by a host or single machine
0010(2)	OFF	OFF	ON	OFF	Set PACK2
0011(3)	OFF	OFF	ON	ON	Set PACK3
0100(4)	OFF	ON	OFF	OFF	Set PACK4
0101(5)	OFF	ON	OFF	ON	Set PACK5
0110(6)	OFF	ON	ON	OFF	Set PACK6
0111(7)	OFF	ON	ON	ON	Set PACK7
1000(8)	ON	OFF	OFF	OFF	Set PACK8
1001(9)	ON	OFF	OFF	ON	Set PACK9
1010(10)	ON	OFF	ON	OFF	Set PACK10
1011(11)	ON	OFF	ON	ON	Set PACK11
1100(12)	ON	ON	OFF	OFF	Set PACK12
1101(13)	ON	ON	OFF	ON	Set PACK13
1110(14)	ON	ON	ON	OFF	Set PACK14
1111(15)	ON	ON	ON	ON	Set PACK15

4.6 Communication Functions

Interface Description:

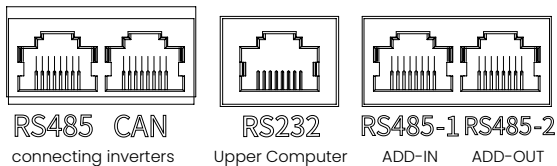

Interface	RS485-1		CAN1		RS232		RS485	
Functional Description	Connection to host computer or inverter		Connection to host computer or inverter		Parallel communication		Parallel communication	
Pin Descriptions	Pin	Descriptions	Pin	Descriptions	Pin	Descriptions	Pin	Descriptions
	1, 8	RS485-B1	1, 8	NC	1, 2, 6	NC	1, 8	RS485-B2
	2, 7	RS485-A1	2, 7	NC	3	TX	2, 7	RS485-A2
	4	NC	4	CANHI	4	RX	4	NC
	5	NC	5	CANLI	5	GND	5	NC(L)/OUT(R)
	3, 6	GND	3, 6	GND			3, 6	GND

4.7 Parallel Wiring Instructions

Interface Illustration:

Unit 1
(Master Device)

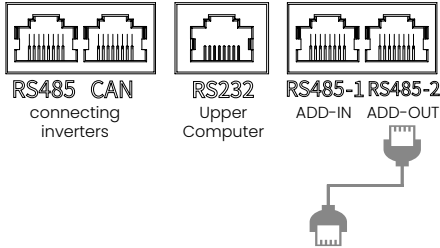

Unit 2
(Slave Device)

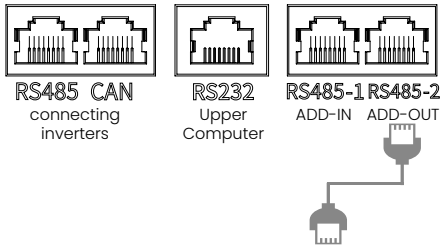

Unit 3
(Slave Device)

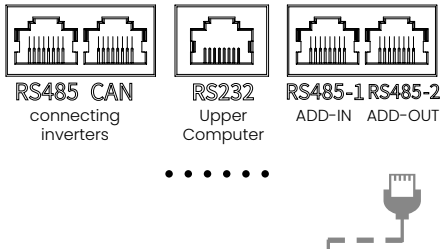

Unit 15
(Slave Device)

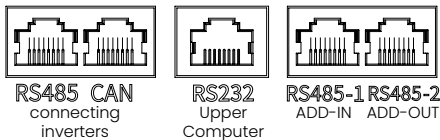

5. Display Description

5.1 Startup and Main Interface

5.1.1 Startup Process

After the device is powered on, the system automatically enters the startup interface, displays a progress bar and the word "Loading..." to complete system initialization. After initialization, it automatically jumps to the main interface (main screen).

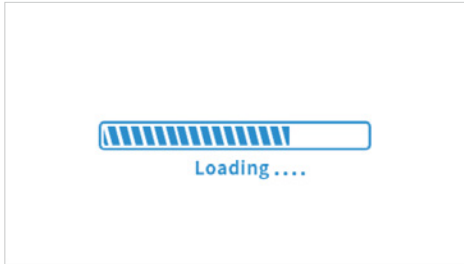

5.1.2 Core Information of Main Interface

The main interface is the core monitoring page of the system, displaying key operating parameters in real time: SOC (State of Charge), Voltage, Current, Capacity, Cell Volt, Cell Temp, Operating Mode, Status Indicator Light.

The main interface is the core entry of the system, and all function menus are accessed through buttons on this interface.

Button 1: Slave Setting

Button 2: Communication Setting

Button 3: System Setting

Button 4: Login / Parameter Setting

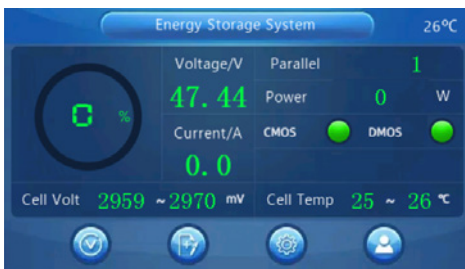

5.2 Button 1: Slave Setting

Function: Calibration and configuration of slave-related parameters to ensure accurate coordinated operation between the slave and the master.

Operation Steps: Click 「Button 1」 on the main interface to enter the slave setting interface.

The interface displays slave parameter configuration items; click the corresponding parameters to complete calibration and configuration. After setting, click 「Select Confirm」

to automatically jump back to the battery information interface (same as the core parameter page of the main interface).



5.3 Button 2: Communication Setting

Function: Configure CAN and RS485 communication interface parameters to realize communication with inverters, upper computers and other equipment.

Operation Steps: Click 「Button 2」 on the main interface to enter the communication parameter configuration interface. The communication addresses of CAN and RS485 can be set separately (example: GROWATT). After configuration, click 「Setting」, and the system performs communication diagnosis: ✓ Normal Communication: Jump to the 「Communication Success Interface」, display a green check mark, indicating that the communication link is normal. ✘ Communication Failure: Jump to the 「Communication Failure Interface」, display a red cross; check the wiring, baud rate, and address configuration, and reconfigure after troubleshooting. After the communication diagnosis is completed, it automatically returns to the main interface.





5.4 Button 3: System Setting

Function: Language switching, screen parameter adjustment, and equipment version information viewing.

Operation Steps: Click 「Button 3」 on the main interface to enter the main system setting interface, which includes 3 sub-menus: 「Language settings」 「Screen settings」 「Version information」.



5.4.1 Submenu 1: Language Setting

Click to enter the language selection interface, which supports multi-language switching (including English, Russian, German, French, Polish, Dutch, Spanish, Thai, Vietnamese, Portuguese, etc.). Click the target language, the system automatically switches the interface language and returns to the main system setting interface.



5.4.2 Submenu 2: Screen Setting

Click to enter the screen parameter interface, where you can adjust the screen brightness and backlight timeout (example: 30 seconds). After adjustment, click 「Confirm」 to save the settings and return to the main system setting interface.



5.4.3 Submenu 3: Version Information

Click to enter the version information interface to view the device's hardware model, software version, serial number (SN) and other information, which is used for device traceability and after-sales maintenance. After viewing, click to return to the main interface.



5.5 Button 4: Login / Parameter Setting

Function: Administrator authority login and battery core parameter configuration (only authorized personnel can operate).

Operation Steps: Click 「Button 4」 on the main interface, a password input keyboard will pop up; enter the administrator password (666888) and then: ✓ Wrong Password: Automatically return to the main interface, remain in the not logged-in state, and cannot modify parameters. ✘ Correct Password: Jump to the logged-in main interface and unlock the parameter setting authority. If you do not enter the password after clicking 「Button 4」 on the main interface, the system will automatically return to the main interface, and you can only view parameters but not modify them.

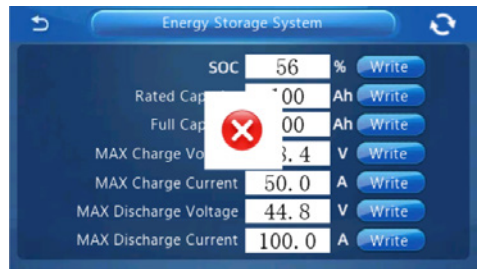
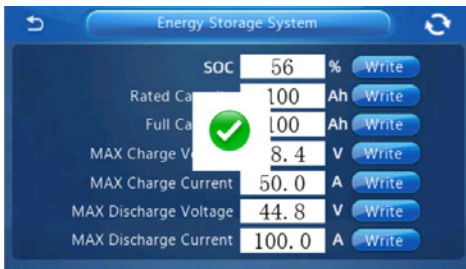
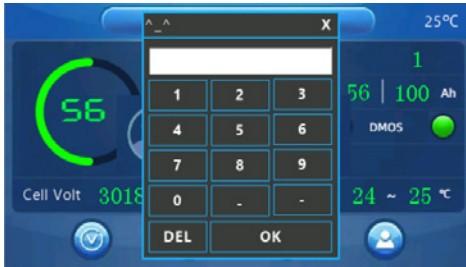
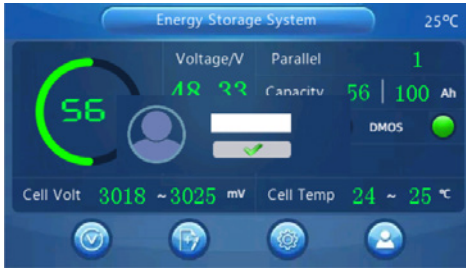

5.5.1 Logged In State (Parameter Setting)

After successful login, enter the parameter setting interface to view / modify the core battery parameters: SOC (State of Charge), Rated Capacity, Full Capacity, Max Charge Voltage, Max Charge Current, Max Discharge Voltage, Max Discharge Current.

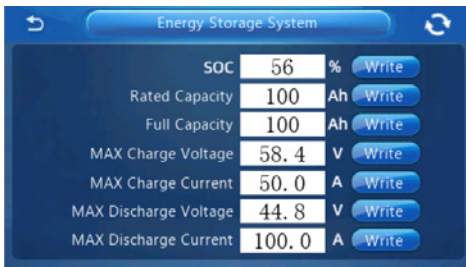

6. Warranty Description

Please read the instructions carefully and keep them in a safe place.

1. This product will be repaired if it malfunctions during the warranty period for normal use in accordance with the operating instructions. The parts replaced during the warranty period are the property of our company.
2. For replacement or warranty, please send this warranty card together with the product.
3. No free repairs will be made during the warranty period if any of the following conditions apply.
 - ① . Damage caused by failure to comply with the requirements of the instruction manual for use, maintenance and repair, or the use of non-original parts.
 - ② . Failure or damage caused by improper storage and custody (product battery failure due to not recharging the product for a long period of time);
 - ③ . Failure or damage caused by the use of power supply equipment and load rated equipment not within the specified voltage range.
 - ④ . Failure or damage caused by private repair, dismantling or modification.
 - ⑤ . Damage to the surface coating and exterior is not covered by the warranty.
 - ⑥ . Product outer packaging and product accessories are not covered by the warranty.
 - ⑦ . Torn, altered or unrecognizable product labels, seals and serial numbers (SN).
4. Failure or damage due to force majeure (force majeure refers to an objective event that cannot be foreseen, avoided or overcome.
This includes natural disasters such as floods, fires, explosions, lightning, earthquakes and storms, as well as social events such as wars and disturbances).
5. This manual is for use only in (this sales area), the final interpretation right belongs to the company.
6. Please keep this manual in a safe place as it will not be distributed separately to users.
7. If the name of the distributor is not written or stamped, ask the distributor from whom you purchased the product for proof of the date of purchase and the name of the distributor, and issue a receipt to the distributor. If you do not have such proof, please contact your dealer or the company from which you purchased the product. If you purchased the product from our online store, please be sure to provide proof of the date of purchase, such as an invoice, order number, or a screen shot of your order history.

7. Reimbursable Service Warranty

Because the product does not meet the warranty conditions need to be charged, the company will be based on parts and labor costs to calculate the appropriate repair costs, and put forward a repair quote to you, after obtaining your consent and payment of the cost to provide repair services for your product.

PRODUCT WARRANTY CARD

This card is a product warranty certificate, please be sure to keep it properly.

Product Name

Manufacturing Number

Purchasing Date

Dealer Name

Dealer Address

Customer Name

Customer Address

Customer Phone Number

Customer Email